



TQB Brands Pty Ltd
**PRICED PRODUCT
 GUIDE**

**MADE FOR THE
 TRADE**

Established 1984
 Trusted by Australia's
 trade for more than
40 YEARS

VALID THROUGH TO
 MARCH 31 2025

WORKSHOP EQUIPMENT



**Portable
 Evaporative
 Cooler 750W**

- One-piece moulded polyethylene housing will not crack and is rust and leak proof.
- Environmentally-friendly alternative to traditional reverse cycle A/C.
- Cools where traditional cooling methods are impractical or cost prohibitive.
- Easy to read water level sight tube gauge.
- Dual pour in refill water inlet and/or 3/4" hose fitting for automatic tap refill.
- Direct drive. LCD 24hour timer panel.
- Nylon castors for easy portability.
- Remote control speed adjustment.



Excludes GST
\$1699
 Inc. GST \$1868.90

240V/50Hz/750W 3 speed motor
 Max. air flow: 23,000 m3 per hour
 Water consumption: 12-18 ltr. per hour
 Effective cooling area: 150-200sqm
 Water tank capacity: 130 Litres
 1730H x 1120W x 680Dmm
 Weight: 63kg

1035T



*Freight Rates May Apply

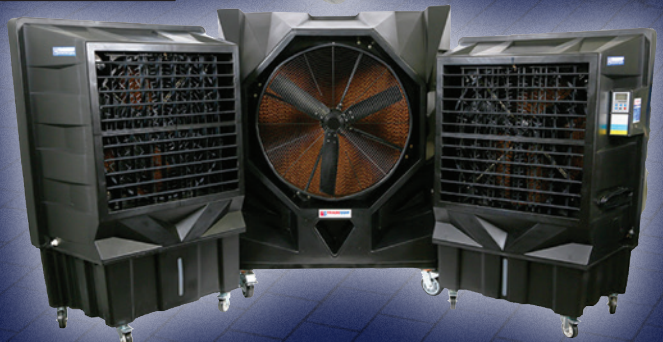

Portable Evaporative Cooler 750W

1029T **TRADEQUIP**
The trusted brand in equipment

240V/50Hz/750W 3 speed motor
Max. air flow: 23,000 m³ per hour
Water consumption: 20-35 litres per hour
Effective cooling area: 200-260sqm
Cooling area: 200-260m²
Water tank capacity: 200 Litres
1800H x 1600W x 780Dmm
Weight: 128kg

MADE FOR THE TRADE

UPGRADED 5 BLADE DESIGN INCREASING AIR VELOCITY



Nylon Castors for easy portability



Remote Control Timer Panel

TRADEQUIP EVAPORATIVE COOLERS FEATURES & BENEFITS

Moulded polyethylene housing will not crack and is rust & leak proof. Environmentally-friendly alternative to traditional reverse cycle A/C. Cools without chemicals or refrigerants. Long-term dependability. Near maintenance free operation. Cools where traditional cooling methods are impractical or cost-prohibitive. Remote control speed adjustment. Direct drive. LCD 24 hour timer panel. Easy to read water level sight tube gauge. Dual pour in refill water inlet and/or 3/4" hose fitting for automatic tap refill. Adjustable water flow & drain valve. Nylon castors for easy portability.



View Range HERE

750 Watts

Excludes GST
\$4899
Inc. GST \$5388.90



*Freight Rates May Apply

Portable Evaporative Cooler 550W

1027T **TRADEQUIP**
The trusted brand in equipment

240V/50Hz/550W 3 speed motor
Max. air flow: 18,000 m³ per hour
Effective cooling area: 100-150sqm
Water consumption: 12-18 litres per hour
Water tank capacity: 100 Litres
1510H x 1120W x 680Dmm
Weight: 58kg

MADE FOR THE TRADE

Portable Evaporative Cooler 750W

1035T **TRADEQUIP**
The trusted brand in equipment

240V/50Hz/750W 3 speed motor
Max. air flow: 23,000 m³ per hour
Effective cooling area: 150-200sqm
Water consumption: 12-18 litres per hour
Water tank capacity: 130 Litres
1730H x 1120W x 680Dmm
Weight: 63kg

MADE FOR THE TRADE

Synchronous Swing Function



Remote Control Timer Panel



550 Watts

Excludes GST
\$1349
Inc. GST \$1483.90

*Freight Rates May Apply

Synchronous Swing Function



Remote Control Timer Panel



750 Watts

Excludes GST
\$1699
Inc. GST \$1868.90

*Freight Rates May Apply

Cooler Cover

1035T-CO **TRADEQUIP**
The trusted brand in equipment

Water-resistant fabric
Lightweight and breathable
UV treated and Easy to use
To protect 1027T, 1028T and 1035T TradeQuip Portable Evaporative Coolers when not in use.

MADE FOR THE TRADE

Excludes GST
\$99
Inc. GST \$108.90



Cooler Maintenance

*Additional Freight Rates may apply

SPOT COOLING AIR CONDITIONERS

Portable Industrial Spot Cooling Air Conditioners



Code	1031T	1032T	1033T
Power Unit	240V 50Hz	240V 50Hz	240V 50Hz
Rated Power	950W	2000W	3000W
Mains Plug	10 Amp	15 Amp	15 Amp
Cooling Capacity	2.7KW/9200Btu	4.5KW/15300Btu	6.5KW/22200Btu
Max. Air Flow	400m3 p/hr	800m3 p/hr	1200m3 p/hr
Noise Level	55dB(A)	60dB(A)	65dB(A)
Operating Temp.	18° - 45° C	18° - 45° C	18° - 45° C
Suction Pressure	2.5Mpa (Max.)	2.5Mpa (Max.)	2.5Mpa (Max.)
Discharge Pressure	4.5Mpa (Max.)	4.5Mpa (Max.)	4.5Mpa (Max.)
Dimensions	855Hx430Wx405D	1035Hx520Wx480D	1245Hx640Wx560D
Excl. GST	\$1299	\$2499	\$3799
Incl. GST	\$1428.90	\$2748.90	\$4178.90

TRADEQUIP INDUSTRIAL AIR CONDITIONERS FEATURES & BENEFITS

Compact yet powerful. Wide operating range of 18° - 45°C.
 Single duct system for easy installation. Capillary tube construction for simplicity.
 5 Litre self-contained condensation tank for easy removal and emptying.
 Heavy duty compressor with automatic restart and short cycle protection.
 Motors and compressors have overload protection.
 Durable and long lasting steel construction.
 Heavy duty locking castors and handles for easy manoeuvrability.
 Easy to use plug in and place the hot air duct out of window/door or into false ceiling.

Industrial Cable Reel 15 Metre



1994T
10 Amp

Great
Accessory
Option



Excludes GST
\$219
Inc. GST \$240.90

MADE FOR THE
TRADE

TradeQuip "Made for the Trade" Portable Air Conditioners offer a quick spot cooling solution with strong air flow and easy installation.

MADE FOR THE
TRADE

from
Excludes GST
\$1299
Inc. GST \$1428.90



Industrial Ventilation Fans



Code	1025	1056	1141T
Fan Diameter	300mm	400mm	450mm
Voltage	240V 50Hz	240V 50Hz	240V 50Hz
Power	520W	1100W	1700W
Speed	2800rpm	2800rpm	2800rpm
Noise Level	92db2 (A)	92db2 (A)	92db2 (A)
Air Delivery	60m ³ per minute	96m ³ per minute	162m ³ per minute
Static Pressure	343Pa	700Pa	972Pa
Excl. GST	\$295	\$735	\$869
Incl. GST	\$324.50	\$808.50	\$955.90

FEATURES

These TradeQuip "Made for the Trade" Industrial Ventilator Fans air out rooms, circulate air or dry wet areas with a powerful air output of 60m³ per minute. Features include an ergonomic handle for effortless transport and an aluminium blade with steel housing construction for long lasting durable performance. Complete with 5 metre flexible ducting.

WARNING: NOT INTENDED FOR DUST EXTRACTION

from
Excludes GST
\$295
Inc. GST \$324.50

MULTI-BLADE ALLOY FANS



Also available separately
5m Flexible Ducting 300, 400 & 450mm diam.
10m Flexible Ducting 300mm diameter only

Industrial Pedestal Misting Fan 650mm

1182T The trusted brand in equipment

240V/50Hz/230W 3 speed motor
90° Oscillation
Water shortage protection.
Drop the temperature: 2-8°C
Adjustable mist-Exit Vol: 0-16KG/Hr
Effective spray distance: 8-10mtr
Suitable for cooling people, stockbreeding or greenhouse applications.

Excludes GST
\$599
Inc. GST \$658.90



FEATURES

Great for workshops and factory floor areas. Adjustable height to 1.8m and 3 speed operation. Large water storage tank & integrated water reservoir. No mess drip water collector. Heavy duty base for safety and stability. Low pressure water pump for reliability and longevity. Automatic shut-off when water tank is empty.



Industrial Pedestal Fan 750mm

1015 The trusted brand in equipment

240V/50Hz/280W 3 speed motor
750mm aluminium 3 blade fan
Adjustable height: 1235-1760mm (Blade centre)
0° to 90° oscillating angle or fixed
Air flow: Up to 300m³/min

Excludes GST
\$210
Inc. GST \$231.00

Cast aluminium blade



280 Watts

Chrome steel cage

FEATURES

Rugged and dependable Direct drive motor requires less power and less maintenance compared to other motors. Durable all-metal construction with black finish, chromium (finger safe) steel grille. Aerodynamically balanced 3 spoke aluminum blades for maximum airflow and motor efficiency. Adjustable tilt to direct air where you need it. Cast iron heavy duty base for stability. Metal oscillating gears.

Cast Iron heavy duty base for stability

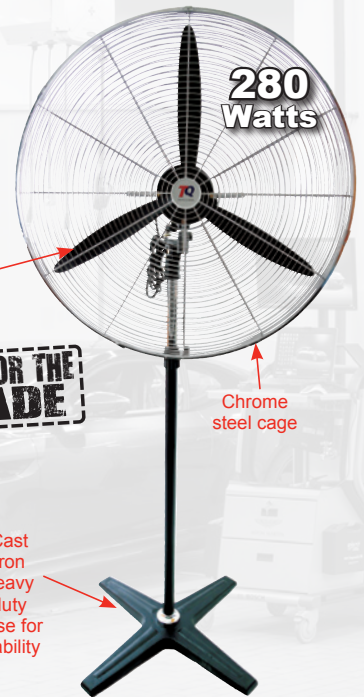

Industrial Wall Mounted Fan 750mm

1026 The trusted brand in equipment

240V/50Hz/280W 3 speed motor
750mm cast alloy 3 blade fan
0° to 90° oscillating angle
Air flow: Up to 300m³/min
Noise level: 86dB(A)

Excludes GST
\$210
Inc. GST \$231.00

Cast aluminium blade



Includes sturdy wall mount bracket

Chrome steel cage

FEATURES
Cast aluminium 3 spoke fan blade. Adjustable tilt and High air flow. Metal oscillating gears. Heavy duty wall mounting bracket.

Industrial Portable Floor Fan 450mm

1045 The trusted brand in equipment

240V/50Hz/220W 3 speed motor
450mm steel 3 blade fan
Adjustable flow angle
Air flow: 142sqm per min
Noise level: 69dB(A)

Excludes GST
\$155
Inc. GST \$170.50



220 Watts

Chrome steel cage

FEATURES

The enclosed direct drive motor is protected from dust and debris to provide years of reliable service. The 3-speed switch gives you control over the airflow, and vertical tilt helps you control angle. Solid metal construction with durable steel blades.



Workshop Trolley (Polymer)

6044T **TRADEQUIP**
The trusted brand in equipment

Safe working capacity: 226kg
Top tray: 778L x 415W x 63Hmm
Tray capacity: 113kg (each)
Smooth rolling rubber castors: 125D x 25Wmm
Ground clearance: 140mm
Weight: 14kg

Excludes GST
\$239
Inc. GST \$262.90

SUPER STRONG POLYMER



MADE FOR THE TRADE

FEATURES

Two deep shelves for plenty of storage.
Will not dent, rust or chip. Convenient push handle.
Two swivel and two fixed smooth rolling rubber castors.
No painting required. Cleans easily. Virtually maintenance free.

Workshop Trolley (Polymer)

6045 **TRADEQUIP**
The trusted brand in equipment

Safe working capacity: 226kg
3 x 100mm deep shelves
125x30mm smooth rolling rubber swivel castors
75kg tool tray capacity
875L x 430W x 830Hmm

Excludes GST
\$263
Inc. GST \$289.30

SUPER STRONG POLYMER



MADE FOR THE TRADE

FEATURES

Deep shelves for plenty of storage.
Will not dent, rust or chip. Convenient push handle.
Two swivel and two fixed smooth rolling rubber castors.
No painting required. Cleans easily. Virtually maintenance free.

Workshop Trolley 3 Tool Trays

6004 **TRADEQUIP**
The trusted brand in equipment

Safe working capacity: 150kg
Powder coated .6mm steel
100mm composite castors
845L x 410W x 780Hmm

Excludes GST
\$171
Inc. GST \$188.10

MADE FOR THE TRADE

150kg Capacity



FEATURES

This three shelf workshop trolley is durable enough for moving tools and car parts.
Deep shelves give you plenty of storage for your tools and parts.

Workshop Trolley 2 Tool Trays & 1 Drawer

6012T **TRADEQUIP**
The trusted brand in equipment

Safe working capacity: 100kg
One lockable drawer
100mm composite rubber castors
Two 100mm deep shelves
770L x 370W x 830Hmm

Excludes GST
\$269
Inc. GST \$295.90

FEATURES

Heavy gauge steel construction.
Quality 35mm ball bearing slide drawer.
Side handle for comfort and control.
Tough enamel finish.

100kg Capacity



MADE FOR THE TRADE

Workshop Trolley (Polymer)

6042T **TRADEQUIP**
The trusted brand in equipment

Safe working capacity: 226kg
Tray: 900L x 600W x 65Hmm
Tray capacity: 113kg (each)
Smooth rolling rubber castors: 125D x 25Wmm
Ground clearance: 140mm
Weight: 22kg

Excludes GST
\$329
Inc. GST \$361.90

MADE FOR THE TRADE



SUPER STRONG POLYMER

FEATURES

Two deep and wide shelves for plenty of storage.
Convenient push handle. Virtually maintenance free.
Two swivel and two fixed smooth rolling rubber castors.
Will not dent, rust or chip. No painting required. Cleans easily.

Workshop Trolley (Polymer)

6043T **TRADEQUIP**
The trusted brand in equipment

Safe working capacity: 226kg
Tray capacity: 76kg (each)
Tray: 900L x 600W x 65Hmm
Smooth rolling rubber castors: 125D x 25Wmm
Ground clearance: 140mm
Weight: 33.5kg

Excludes GST
\$379
Inc. GST \$416.90

MADE FOR THE TRADE



SUPER STRONG POLYMER

FEATURES

Three deep and wide shelves for plenty of storage.
Convenient push handle. Virtually maintenance free.
Two swivel and two fixed smooth rolling rubber castors.
Will not dent, rust or chip. No painting required. Cleans easily.

Workshop Trolley (Polymer)

6046 **TRADEQUIP**
The trusted brand in equipment

Safe working capacity: 226kg
8 Parts bins 241x152x127mm
24 Parts bins 165x101x76mm
125x30mm rubber swivel castors
85kg tool tray capacity
1000L x 435W x 850Hmm

Excludes GST
\$365
Inc. GST \$401.50

SUPER STRONG POLYMER

MADE FOR THE TRADE



Includes 32 Parts Bins

FEATURES

Deep shelves give you plenty of storage for your tools and parts.
Industrial grade castors.
Will not dent, rust or chip.
Convenient push handles.
No painting required. Cleans easily.

Transmission Lifter Passenger Vehicles

2059T **TRADEQUIP**
The trusted brand in equipment

Safe working capacity: RWD/FWD GVM <2,000KG
Rated capacity: 500kg
Working height: 820-1768mm
Forward tilt: 9° Rearward tilt: 17°
Weight: 52kg



Excludes GST
\$799
Inc. GST \$878.90



Transmission Lifter Passenger Vehicles

2022T **TRADEQUIP**
The trusted brand in equipment

Safe working capacity: RWD/FWD/AWD GVM <2,300KG
Rated capacity: 500kg
Working height: 895-1875mm
Cradle size: 240 x 340mm
Tilt Angle: Left 7° Right 15°
Weight: 73kg



FEATURES
High-grade steel for quality and durability. Lead-free paint prevents rust and is oil, grease and dirt-resistant for easy cleanup. Universal mounting cradle provides wide fore & aft tilt. High quality large diam. hydraulic steel cylinder unit. Piston-ram treated & polished to extend service life.

Excludes GST
\$945
Inc. GST \$1039.50



Transmission Lifter Passenger Vehicles

2052 **TRADEQUIP**
The trusted brand in equipment

Safe working capacity: RWD/FWD/AWD GVM <2,500KG
Rated capacity: 500kg
Working height: 855-1760mm
Cradle size: 276 x 360mm
2 Stage lift
4 way tilting working head
Tilt: Fwd 15° Rwd 7° Lat 7°
Base: 690 x 780mm
Weight: 61kg

FEATURES
High-grade steel for quality and durability. Lead-free paint prevents rust and is oil, grease and dirt-resistant for easy cleanup. Universal mounting cradle provides wide fore & aft tilt. High quality large diam. hydraulic steel cylinder unit. Piston-ram treated & polished to extend service life.



Transmission Lifter SUV / 4x4 & Light Commercial

2063T **TRADEQUIP**
The trusted brand in equipment

Safe working capacity: RWD/FWD/AWD/4X4 GVM <3,200KG
Rated capacity: 1,000kg
Working height: 940-1920mm
Lift platform size: 280 x 280mm
Tilt: Fwd 15° Tilt Rwd 10°
Tilt: Side 9° Tilt Side 11°
Weight: 82kg

FEATURES
High-grade steel for quality and durability. Lead-free paint prevents rust & is oil, grease and dirt-resistant for easy cleanup. Universal mounting cradle gives wide fore & aft tilt. High quality large diam. hydraulic steel cylinder. Polished & treated Piston-ram extends service life.

Excludes GST
\$1259
Inc. GST \$1384.90



WARNING INTENDED USE: Removal & Installation of Transmissions
NOT INTENDED FOR: Supporting Loads i.e. Fuel Tanks, Suspension Work, BullBar Installations

*Additional Freight Rates may apply

TRANSMISSION LIFTERS

Transmission Lifter Passenger Vehicles

PROTL500

Safe working capacity:
RWD/FWD/AWD GVM <2,500KG
Rated capacity: 500kg
Working height: 940-1940mm
Ram travel 1st stage: 490mm
Ram travel 2nd stage: 510mm
Tilt: Fwd 9° Rwd 28° Left 9° Right 28°
Base: 610 x 740mm
Weight: 65kg

LATEST APPLIED TECHNOLOGIES
TQ Pro
Trusted by serious professionals

Professional Reputable Outstanding



Transmission Lifter SUV / 4x4 & Light Commercial

2057T **TRADEQUIP**
The trusted brand in equipment

Safe working capacity:
RWD/FWD/AWD/4X4 GVM <3,500KG
Rated capacity: 1,000kg
Working height: 205-725mm
Cradle size: 340 x 200mm

MADE FOR THE TRADE

Tilt: Fwd 70° Rwd 15°
Cradle lateral adjustment: 90mm
Chassis: 850L x 490W x 305Hmm
Weight: 54kg

FEATURES

Adjustable head (forward & backward).
Lateral cradle adjustment.
Hydraulic system overload protection.
Four (4) swivel castors allow easy movement and positioning of transmission jack.
Rugged heavy duty steel wheels with full swivel ball bearing castors.
User-friendly 360° rotating pump handle.



Transmission Lifter SUV / 4x4 & Light Commercial

PROTL1000

Safe working capacity:
RWD/FWD/AWD/4X4 GVM <3,500KG
Rated capacity: 1,000kg
Working height: 940-1940mm
Ram travel 1st stage: 490mm
Ram travel 2nd stage: 510mm
Tilt: Fwd 9° Rwd 28° Left 9° Right 28°
Base: 610 x 740mm
Weight: 76.5kg

LATEST APPLIED TECHNOLOGIES
TQ Pro
Trusted by serious professionals

Professional Reputable Outstanding



Transmission Lifter Commercial Vehicles

BHDTJ2 **BORUM**
INDUSTRIAL WORKSHOP EQUIPMENT

Safe working capacity: 2,000kg
Working height: 210-900mm
Cradle size: min. 385-470mm
Cradle size: max. 570-470mm
Adjustable tilt cradle
Cradle forward tilt: 30°
Cradle backward tilt: 30°
Swivel castors: 100mm
Chassis: 1160L x 685Wmm
Weight: 130kg

FEATURES

The adjustable cradle can be tilted forward or backward for optimum alignment of transmission bolt patterns and pins.
Hydraulic system is protected from overload damage.
Safety load-restraint for raising & lowering safety.
Rugged steel wheels & full swivel ball bearing castors.
User-friendly 360° rotating pumping handle.

INDUSTRIAL QUALITY

Excludes GST \$2111
Inc. GST \$2322.10



WARNING

INTENDED USE: Removal & Installation of Transmissions
NOT INTENDED FOR: Supporting Loads i.e. Fuel Tanks, Suspension Work, BullBar Installations

Auxiliary Lifter 500KG

2058T **TRADEQUIP**
The trusted brand in equipment

Rated capacity: 500kg
Working height: 1175-1985 mm
Lifting platform size:
A: 362 x 362mm
B: Φ 107.5mm



FEATURES

This TradeQuip "Made for the Trade" 500kg Auxiliary Lifter is the perfect underhoist aid during removal and installation of small components. It features a mounting cradle and lift pad and a manually operated hydraulic system with smooth hydraulic lift and descent. The hydraulic system also includes a bypass system to prevent over extension and accidental overloading.

MADE FOR THE TRADE

Excludes GST
\$489
Inc. GST \$537.90

500kg Capacity

NOT INTENDED FOR SUPPORTING LOADS AND NOT INTENDED AS STAND ALONE TRANSMISSION LIFTER



MADE FOR THE TRADE

Auxiliary Lifter Kit 500KG

2068T **TRADEQUIP**
The trusted brand in equipment

Rated capacity: 500kg
Working height: 1175-1985 mm
Lifting platform size:
A: 362 x 362mm
B: Φ 107.5mm
C: 812 X 352mm

500kg Capacity

Excludes GST
\$679
Inc. GST \$746.90

NOT INTENDED FOR SUPPORTING LOADS AND NOT INTENDED AS STAND ALONE TRANSMISSION LIFTER

Underhoist Auxiliary Stand 680KG

1198T **TRADEQUIP**
The trusted brand in equipment

Safe working capacity: 680kg
Height: 1370-2045mm
Base diameter: 300mm
Weight: 16.5kg



FEATURES

Fast and safe technology for professional mechanics.
Heavy gauge steel frame prevents distortion or twisting.
Provides partial support for components - NOT designed to support the vehicle.
Foot pedal allows easy load movement and hand free operation.
Quick action adjustable height mechanism.
Sold individually recommended only to be used individually.

Excludes GST
\$195
Inc. GST \$214.50

Hands free foot pedal operation

680kg Capacity

MADE FOR THE TRADE

Top Tips

Product information



Scan code to go to our Top Tips Transmission Lifter Guide and learn how to extend the life of your TQB Brands equipment



Visit our webpage www.tqbbrands.com.au for instructional & pre-start videos.

Scissor Lift Workshop Trolley 500KG

6007T **TRADEQUIP**
The trusted brand in equipment.

Safe working capacity: 500kg
Working height: 440-1575mm
Table size: 1010L x 520Wmm
Wheel diameter: 150mm
Dimensions: 1130L x 520W x 1260Hmm

FEATURES

Double Scissor High Lift.
Foot-operated hydraulic pedal keeps your hands free.
Quick release hand lever for easy, controlled hydraulic release.
2 locking heavy duty swivel castors.
All steel construction.
Powder coated for extra protection.
Perfect for moving heavy parts to and from the vehicle.

MADE FOR THE TRADE



DOUBLE SCISSOR HIGH LIFT

500kg Capacity

Excludes GST
\$1629
Inc. GST \$1791.90

Scissor Lift Workshop Trolley 450KG

6003T **TRADEQUIP**
The trusted brand in equipment.

Safe working capacity: 450kg
Working height: 280-875mm
Table size: 500 x 810mm
Wheel Diameter: 125mm
Dimensions: 1140L x 515W x 995Hmm

FEATURES

Hands free foot-operated hydraulic pedal.
Quick release hand lever.
Heavy duty oil-resistant nonslip mat.
Powder coated all steel construction.
Perfect for moving heavy parts to vehicles.



450kg Capacity

Excludes GST
\$898
Inc. GST \$987.80

MADE FOR THE TRADE

FOLDABLE HANDLE

Scissor Lift Workshop Trolley 300KG

6008T **TRADEQUIP**
The trusted brand in equipment.

Safe working capacity: 300kg
Working height: 350mm-1285mm
Table size: 820L x 520Wmm

Excludes GST
\$1049
Inc. GST \$1153.90

MADE FOR THE TRADE

DOUBLE SCISSOR HIGH LIFT

FEATURES

Hands free foot-operated hydraulic pedal.
Heavy duty oil-resistant nonslip mat.
Powder coated all steel construction.
Perfect for moving parts to vehicles.



300kg Capacity

Scissor Lift Workshop Trolley 500KG

6009T **TRADEQUIP**
The trusted brand in equipment.

Safe working capacity: 500kg
Working height: 265mm-865mm
Table size: 820L x 520Wmm

Excludes GST
\$829
Inc. GST \$911.90

MADE FOR THE TRADE

FEATURES

Hands free foot-operated pedal.
Quick release hand lever for easy, controlled release.
Heavy duty oil-resistant nonslip mat.
Powder coated all steel construction.
Perfect for moving parts to vehicles.



500kg Capacity

Scissor Lift Workshop Trolley 225KG

6010T **TRADEQUIP**
The trusted brand in equipment.

Safe working capacity: 225kg
Working height: 225mm-710mm
Table size: 708L x 450Wmm

Excludes GST
\$449
Inc. GST \$493.90

MADE FOR THE TRADE

FEATURES

Hands free foot-operated pedal.
Quick release hand lever for easy, controlled release.
Heavy duty oil-resistant nonslip mat.
Powder coated all steel construction.
Perfect for moving parts to vehicles.



225kg Capacity

Steel Workbench

1014T **TRADEQUIP**
the trusted brand in equipment

Safe working capacity: 90kg
Work surface: 1510x700mm
Raised edge height: 50mm
1520L x 710W x 830Hmm
Weight: 48kg

FEATURES

Sturdy steel construction.
High gloss enamel paint finish.
Raised protective edge to work surface.
Adjustable feet for levelling on uneven floors.
Quick and easy to assemble.
Easily wipe dirt and grime from surface with a soft cloth.



3 Drawer Steel Workbench

1012T **TRADEQUIP**
the trusted brand in equipment

Safe working capacity: 300kg
Heavy duty steel construction
High gloss enamel paint finish
Includes bottom shelf & 3 locking drawers
Each drawer holds up to 50kg
2000L x 860H x 640Wmm

FEATURES

Manufactured from high quality, heavy-duty steel and features a large surface for more work space and an extended lip around the surface of the table.
The tough high gloss enamel paint finish is designed to provide years of protection against normal wear and tear.



Mobile Bench

1073T **TRADEQUIP**
the trusted brand in equipment

Safe working capacity: 300kg
Work surface: 1100 x 700mm
1100L x 700W x 830H mm
Weight: 60kg

FEATURES

Sturdy steel construction.
High gloss enamel finish.
Quality castors - two fixed and two locking swivel.
Heavy-duty handle.

300kg Capacity

Versatile and undeniably strong, TradeQuip workbenches are developed with sophisticated designs to endure demanding industry and heavy duty commercial applications.



Mobile Workbench

6047 **TRADEQUIP**
the trusted brand in equipment

Safe working capacity: 250kg
Bench top capacity: 150kg
Bench top: 1200L x 640Wmm
1200L x 640W x 875H mm
Shelf: 1110L x 460Wmm
Shelf capacity: 100kg
Weight: 56.5kg

MADE FOR THE TRADE

Excludes GST

\$711

Inc. GST \$782.10

FEATURES

Heavy duty rolled edge steel construction.
Convenient removable drain bowl.
13mm benchtop rim to contain leaking fluids when working on engines and transmissions.
Quality castors (2 swivel with brake).
Lockable steel drawer with ball bearing slides.
High gloss enamel paint finish.



Steel Wall Mounted Tool Cabinet

1011T **TRADEQUIP**
the trusted brand in equipment

Thickness: 1mm Steel Sheet
Lockable cupboards: 3
Adjustable shelves: 6
Peg board hooks: 6
1200L x 600H x 200W mm
Weight: 19kg

MADE FOR THE TRADE

FEATURES

Three compartments each have 2 adjustable shelves.
Perforated & slotted back panel to allow for the hanging of tools.
High gloss enamel paint.
Includes mounting brackets.



Mobile Workshop Table

6024T **TRADEQUIP**
The trusted brand in equipment

Safe working capacity: 45kg
Working height: 930-1270mm
Castor wheel diameter: 75mm
Top dimensions: 809L x 475W x 42Hmm
Main tray dimensions: 580L x 308W x 38Hmm
Overall dimensions: 870L x 755W x 942Hmm
Weight: 19.5kg

FEATURES
The Heavy Duty steel construction. Easily handles loads up to 45kg. Solid composite rubber castors. Simple height adjustment gives you plenty of options for lowered cars or SUVs.

Excludes GST
\$349
Inc. GST \$383.90

Lockable composite rubber castors

MADE FOR THE TRADE

45kg Capacity

Foam Protector



Mobile Workshop Table with Drawer

6056T **TRADEQUIP**
The trusted brand in equipment

340x300x45mm drawer
Adjustable from 860-1200mm high
Includes drawer and top tray liner
80kg Distributed load capacity
730x500x25mm top tray

FEATURES
Height adjustable for most vehicles. Ball Bearing wheels for easy moving. Multi-functional top table with 3 compartments and 6 screwdriver holes. Top EVA mat for skid resistance. Extra drawer for more storage room.

MADE FOR THE TRADE

Excludes GST
\$259
Inc. GST \$284.90



Workshop Trolley 2 Drawers & Lockable Sliding Top

6019T **TRADEQUIP**
The trusted brand in equipment

Safe working capacity: 100kg
Two lockable drawers & top
100mm composite rubber castors
Two 75mm deep shelves
700L x 370W x 760Hmm

FEATURES
Heavy gauge steel construction with lockable sliding top. Quality 35mm ball bearing sliding drawers, which are locked when top is closed. Side handle for comfort/control when moving. Tough enamel finish. Non slip rubber tool tray liners.

22 Bin Parts Storage Rack

6053 **TRADEQUIP**
The trusted brand in equipment

Working load capacity: 100kg
15 parts bins: 345x105x75mm (3kg load capacity)
4 parts bins: 345x140x150mm (5kg load capacity)
3 parts bins: 345 x 205 x 150mm (8kg load capacity)
Swivel castor diameter: 100mm
880L x 410W x 950H mm

Excludes GST
\$418
Inc. GST \$459.80

FEATURES
Sturdy five-tier steel powder coated rack. Zinc plated wire shelving with bin locating guides. Quick & easy clip together adjustable shelves. Stackable bins made of moulded polypropylene. Ideal for garage, workshop, office, shed. Powder coat frame resists corrosion. Quality swivel castors (2x lockable). Convenient access to removable bins.

EASY TO ASSEMBLE



Excludes GST
\$373
Inc. GST \$410.30

Workshop Trolley 4 Drawers with Lockable Top

6052 **TRADEQUIP**
The trusted brand in equipment

Working load limit: 260kg
Heavy duty steel construction
High gloss enamel paint finish
Non-slip rubber tool tray liners

FEATURES
Quality ball bearing slide drawers, that are locked when top is closed. Two heavy-duty locking castors for control and stability.

MADE FOR THE TRADE

Excludes GST
\$448
Inc. GST \$492.80

Includes bottom shelf and 4 locking drawers
850L x 445D x 972Hmm



36 Bin Parts Storage Rack

6054 **TRADEQUIP**
The trusted brand in equipment

Working load capacity: 200kg
15 parts bins: 345x105x75mm (3kg load capacity)
12 parts bins: 345x140x150mm (5kg load capacity)
9 parts bins: 345 x 205 x 150mm (9kg load capacity)
Swivel castor diameter: 100mm
880L x 410W x 1705Hmm

Excludes GST
\$655
Inc. GST \$720.50

FEATURES
Sturdy nine-tier steel powder coated rack. Zinc plated wire shelving with bin locating guides. Quick & easy clip together adjustable shelves. Stackable bins made of moulded polypropylene. Ideal for garage, workshop, office, shed. Powder coat frame resists corrosion. Quality swivel castors (2x lockable). Convenient access to removable bins.

EASY TO ASSEMBLE



Garage Jack 3,000KG Low Profile

2906T **TRADEQUIP**
The trusted brand in equipment

Working load limit: 3,000kg
Height: 118 - 488mm
Handle length: 1400mm
Front wheels: 90mm dia 40mm width
Rear castors: 60mm dia 25mm width
Saddle diameter: 115mm
Dimensions: 670L x 380W x 170Hmm
Weight: 43kg



MADE FOR THE TRADE

FEATURES
Low profile and deep reach.
Heavy gauge steel construction.
1400mm long handle for deeper reach.
Quick Lift Dual Pump technology.
Internal bypass valve overload protection.
Lead-free paint finish to ensure a long-lasting finish and prevent rust.
Paint is oil, grease and dirt-resistant.
Protective foam handle cover prevents vehicle damage.

TESTED IN AUSTRALIA
MEETS MANDATORY
AS2615:2016

HIGH LIFT - LOW PROFILE AND DEEP REACH



118mm min. lift height

Protective foam handle cover

Excludes GST
\$499
Inc. GST \$548.90

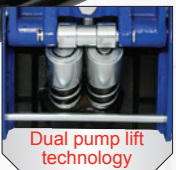

Mechanics Creeper Caddy

TQTC1220 **TRADEQUIP**
The trusted brand in equipment

Safe working capacity: 25kg
Tray depth: 43mm (inner)
Swivel castors: 4x 50D x 16Wmm
435L x 400W x 120Hmm
(castor included)

MADE FOR THE TRADE

FEATURES
Easy to clean finish that is oil and solvent resistant and won't rust.
4 smooth-rolling swivel castors.
Impact resistant polymer plastic.
Built-in parts/tool storage compartments.



Excludes GST
\$45
Inc. GST \$49.50

Ratcheting Positioning Jacks

1054T **TRADEQUIP**
The trusted brand in equipment

Safe working capacity: 680kg each
Max. distance between rollers: 710mm
Min. distance between rollers: 340mm
Suits tyres up to: 280mm (W)
Swivel castors: 100mm

FEATURES
Steel construction with metal rollers.
Heavy duty nylon swivel castors.
Easy foot-pedal lifting design.
2 jacks permit full 180° vehicle pivot.
4 jacks place vehicle on a 360° rolling platform.
Lead-free paint finish helps prevent rust and is oil, grease and dirt-resistant for easy cleanup.
Quick action adjustable height mechanism.
Sold & recommended only to be used in pairs.

MADE FOR THE TRADE

Heavy duty nylon swivel castors

Easy foot pedal lift



Excludes GST
\$469
Inc. GST \$515.90

pair

Mechanics Creeper 130KG

1023T **TRADEQUIP**
The trusted brand in equipment

Safe working capacity: 130kg
1010L x 475W x 115Hmm

MADE FOR THE TRADE

Excludes GST
\$88
Inc. GST \$96.80



FEATURES
The creeper body is manufactured to "Made for the Trade" quality using a high-impact polymer material that resists impacts, won't rust and is easy to clean.
Comfortable padded headrest and load capacity of up to 130kg, this low-profile creeper is one of the lightest and most durable available.

Convenient tool trays on each side

Car and 4WD Jack Stands

TRADEQUIP
The trusted brand in equipment

FEATURES
Constructed of high-grade steel & built to exacting standards for quality & durability.
Lead-free paint finish is oil, grease and dirt-resistant for easy cleanup.
Quick action adjustable height mechanism.
Double-lock safety pin design for extra safety and security. (1128T & 1148T).
Welded steel frame & cast iron support.
Adjustable height.
Reinforced shaft for added strength stability.
Sold in pairs and only recommended to be used in pairs.

MADE FOR THE TRADE



from
Excludes GST
\$99
Inc. GST \$108.90

Quick Action Adjustable Height

Code	1128T	1148T	1162T
Load limit	2,000kg	4,000kg	8,000kg
Min. Height	285-428mm	395-605mm	468-715mm
Base Area	206x186mm	287x252mm	324x294mm
Excl. GST	\$99	\$174	\$295
Incl. GST	\$108.90	\$191.40	\$324.50



4000kg Capacity

8000kg Capacity

2000kg Capacity

*Additional Freight Rates may apply

TYRE LIFTER/DOLLY

Wheel Tyre Lifter

1055T **TRADEQUIP**
The trusted brand in equipment

Safe working capacity: 50kg
 Rollers moving distance: 125mm
 Roller diameter & length: (D) 76.2 x 240mm
 Rollers push force: <4kg based on 50kg load
 Lifting handle force: 1kg based on 50kg load
 Overall height: 1380mm
 Overall base dimensions: 725W x 872D mm
 Roller working range: 100mm to 1060mm
 Front castors: 2(D) 75 x 24mm
 Rear castor - Locking: 2(D) 75 x 24mm
 Weight: 51.25kg

The lifters drive screw can be activated by an air or battery-operated ratchet wrench from the top of the unit.

TRULY MOBILE...
NO ADDITIONAL AIR LINE
OR CHARGING CABLES
NEEDED

FEATURES

Braked Swivel Castor.
 Sturdy Frame to safely transport wheel around workshop.
 Adjustable Safety Brace.

Excludes GST
\$1059
 Inc. GST \$1164.90

50kg Capacity



Wheel Dolly Single 250KG

B250WH **BORUM**
INDUSTRIAL WORKSHOP EQUIPMENT

Safe working capacity: 250kg
 Maximum depth: 305mm
 Overall height: 1000mm
 Weight: 14kg

INDUSTRIAL QUALITY

250kg Capacity

FEATURES

Adjustable arms.
 Equipped with rollers for easy positioning.
 Stop rollers on the rear side.
 Ergonomic handle with rounded & soft safety grip.

This BORUM WHEEL DOLLY is a sturdy & handy transport aid for various types of wheels (trucks, vans, utes and cars). This versatile and easy to operate piece of equipment features adjustable arms. Equipped with two wheels and an ergonomic handle, the units manoeuvrability is not hampered by the size of the wheel.

Excludes GST
\$399
 Inc. GST \$438.90



Truck Wheel Lifter

BTWD750 **BORUM**
INDUSTRIAL WORKSHOP EQUIPMENT

Safe working capacity: 750kg
 Lift arm spread: 533-635mm
 Lifting range: 60-275mm
 Tilt range: -2.5 to 10 degrees
 787L x 1092W x 895H mm

750kg Capacity

INDUSTRIAL QUALITY

Excludes GST
\$969
 Inc. GST \$1065.90



Suitable for Buses and Trucks

Truck Wheel Nut Wrench Torque Multiplier

8033 **TRADEQUIP**
The trusted brand in equipment

1" Drive hand winder operated
 Trans-speed ratio: 1:56
 27mm, 32mm, 33mm, 41mm wheel nut sockets
 Torque output: 4800Nm

MADE FOR THE TRADE

Suitable for Buses and Trucks



Excludes GST
\$169
 Inc. GST \$185.90

INDIVIDUAL SOCKETS AVAILABLE



MADE FOR THE TRADE

1540mm

4 position adjustable boom

Heavy duty hydraulic pump

Heavy Duty Castor Wheels

1470-2385mm

785-875mm

HEAVY DUTY

Engine Crane 3,000KG

1193 **TRADEQUIP**
The trusted brand in equipment

Safe working capacity: 3000kg
Adjustable boom: 1000kg, 1500kg, 2000kg & 3000kg
Maximum lifting height @ 3000kg: 1745mm
Maximum lifting height @ 1000kg: 2088mm
Jib length fully retracted @ 3000kg: 1100mm
Jib length fully extended @ 1000kg: 1730mm
Leg height 190mm
Weight: 121.5kg

FEATURES

This heavy duty TradeQuip "Made for the Trade" engine crane has a long stroke lifting ram, a single action pump with a maximum load capacity of 3,000kg. Very simple to use manual hydraulic operation. The jib extends to the desired lifting capacity of 1000kg, 2000kg or 3000kg secured by a single locking pin. Mounted on heavy duty castor wheels for excellent manoeuvrability around the workshop.

Excludes GST
\$1238
Inc. GST \$1361.80

3000kg Capacity



Engine Stand

1894T **TRADEQUIP**
The trusted brand in equipment

Safe Working Capacity: 4/5/6/V6 cylinder less than 4ltr
Rated capacity: 500kg
360° rotating head
1190L x 850W x 1230H mm
Weight: 54kg

Excludes GST
\$789
Inc. GST \$867.90

WORM GEAR HEAD DRIVE STURDY REINFORCED NECK

360° rotating head

IMPORTANT:
ENGINE DIMENSIONS MUST BE WITHIN LEGS OF ENGINE STAND



Engine Stand

1891T **TRADEQUIP**
The trusted brand in equipment

Safe working capacity: 4cylinder & V6/V8 less than 5ltr
Rated capacity: 680kg
360° rotating head
Centre height: 895mm
870L x 800W x 900H mm
Weight: 39kg

MADE FOR THE TRADE

Removable legs

Excludes GST
\$267
Inc. GST \$293.70

MADE FOR THE TRADE

360° rotating head

Engine Stand

TQES450 **TRADEQUIP**
The trusted brand in equipment

Safe working capacity: 4cylinder engine only
Rated capacity: 450kg
360° rotating head
Centre height: 780mm
700L x 750W x 860H mm
Weight: 21kg

IMPORTANT:
ENGINE DIMENSIONS MUST BE WITHIN LEGS OF ENGINE STAND

SPACE SAVING COMPACT DESIGN EASY SETUP & DISASSEMBLY

Excludes GST
\$159
Inc. GST \$174.90

MADE FOR THE TRADE

360° rotating head

Engine Stand

1192T **TRADEQUIP**
The trusted brand in equipment

Safe working capacity: 4/5/6/V6/V8 Cylinder less than 6.2ltr
Rated capacity: 900kg
360° rotating head
Centre height: 800mm
1110L x 530W x 900H mm
Weight: 45kg

MADE FOR THE TRADE

Excludes GST
\$328
Inc. GST \$360.80

FOLDING LEGS STURDY REINFORCED NECK AND STABLE WIDE BASE

ALL TRADEQUIP ENGINE STANDS ARE INTENDED FOR PASSENGER AND LIGHT COMMERCIAL VEHICLES ONLY

FOLDING STABILISER ARMS

DUAL ACTION HIGH SPEED RAM

1200kg Capacity

1565mm

1690mm

1028mm

MEETS AUSTRALIAN STANDARD AS1418.5

Foldable Engine Crane 1,200KG

1001T **TRADEQUIP**
The trusted brand in equipment

Safe working max. capacity: 1200kg (AS1418.5 approved)
Adjustable boom: 250kg, 500kg, 750kg & 1200kg
Max. lifting height @ 1200kg: 620mm
Max. lifting height @ 250kg: 1160mm
Jib length fully retracted @ 1200kg: 1040mm
Jib length fully extended @ 250kg: 1580mm
Leg height: 190mm
Weight: 85kg



FEATURES

- Ideal for automotive & light engineering.
- Adjustable boom in four positions.
- Outtrigger legs easily fold up for storage.
- Six swivel castor wheels.
- High-grade steel and built to exacting standards for quality and durability.
- Short lifting chain & hook with safety latch.
- Lead-free paint is oil, grease and dirt-resistant for easy cleanup.



Engine Support Bar

1021T **TRADEQUIP**
The trusted brand in equipment

Safe working capacity: 500kg
Extension: 1020 - 1630mm
Weight: 23kg

FEATURES

- Cross bar feature for improved stability and more flexibility.
- Dual hook assemblies for balanced support of engines & transmissions.
- High gloss enamel finish.
- Adjustment screw for leveling.

500kg Capacity

DUAL HOOK

Excludes GST
\$245
Inc. GST \$269.50

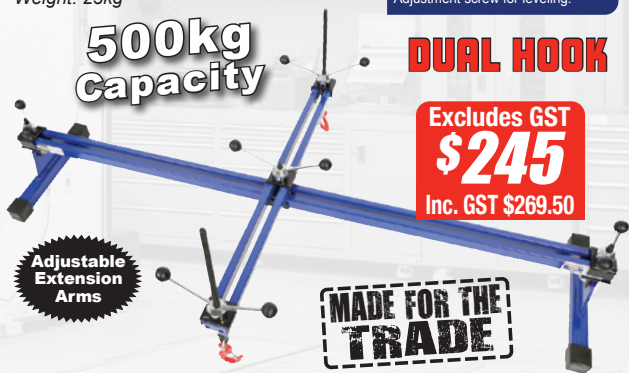

680kg Capacity

Excludes GST
\$93
Inc. GST \$102.30

MADE FOR THE TRADE

Engine Crane Load Leveller

1030 **TRADEQUIP**
The trusted brand in equipment

Safe working capacity: 680kg
Chain length: 300mm
Chain anchor positions: 3
Engine mount positions: 4
Weight: 6kg

Ram to Suit TradeQuip 1001T Engine Crane

2008 **TRADEQUIP**
The trusted brand in equipment

Safe working capacity: 8,000kg
Length: 630-1135mm
Ram pin hole: 16mm dia. 35mm Outside ram
Ram diameter: 80mm
Clevis base pin hole: 16mm dia
Clevis base: 25mm inside - 45mm outside
Base width: 129mm
Weight: 10.5kg

Excludes GST
\$164
Inc. GST \$180.40

8000kg Capacity



Engine Support Bar

1019T **TRADEQUIP**
The trusted brand in equipment

Safe working capacity: 500kg
Extension: 1020 - 1600mm
Weight: 15kg

FEATURES

- Adjusts to fit across most car bonnets.
- Supports engines or transmissions.
- Powder coat finish.
- Adjustment screw for load leveling.
- Supplied with short length of chain.

500kg Capacity

Adjustable Extension Arms

Excludes GST
\$169
Inc. GST \$185.90

Engine Support Bar

1020T **TRADEQUIP**
The trusted brand in equipment

Safe working capacity: 500kg
Extension: 1020- 1430mm
Weight: 19kg

FEATURES

- Dual hook assemblies for balanced support.
- Adjustable to fit across most car bonnets.
- Supports engines or transmissions.
- Rubber cushioned support legs.
- High gloss enamel finish.
- Adjustment screw for load leveling.
- Supplied with a short length of chain.

Adjustable Extension Arms

500kg Capacity

DUAL HOOK





BORUM BOTTLE JACK FEATURES

Manufactured of superior-grade steel and built to exacting standards for quality and durability. Lead-free paint finish is oil, grease and dirt-resistant. Built-in by-pass device protects hydraulic system. Compact, powerful Air Turbo Motor. High quality large diameter hydraulic steel cylinder. Precision machined, chrome plated and polished piston-ram. Versatile "quick connector" for easy removal of air hose.

YouTube
Scan code for online product maintenance demonstration

Air/Hydraulic Bottle Jack 20,000KG

BTSJ20TB INDUSTRIAL WORKSHOP EQUIPMENT

Safe working capacity: 20,000kg
Working height: 262 - 504mm
Hydraulic lift: 163mm
Op. air pressure: 110-125psi
Air inlet fitting: 1/4"
Weight: 16kg

Excludes GST
\$349
Inc. GST \$383.90

20,000kg Capacity

INDUSTRIAL QUALITY



Air/Hydraulic Bottle Jack 20,000KG

PROBJ20TA

Safe working capacity: 20,000kg
Working height: 261.5-525mm
Hydraulic lift: 156mm
Adjustable lift: 95mm
Operating air pressure: 110-125psi
Air inlet fitting: 1/4"
Base: 230 x 150 x 30mm
Weight: 19kg

LATEST APPLIED TECHNOLOGIES
TQ Pro
Trusted by serious professionals

Professional Reputable Outstanding

Excludes GST
\$449
Inc. GST \$493.90

WELDED BASE



20,000kg Capacity

Air/Hydraulic Bottle Jack 20,000KG

BWBBJ20T INDUSTRIAL WORKSHOP EQUIPMENT

Safe working capacity: 20,000kg
Working height: 263 - 503mm
Hydraulic lift: 160mm
Adjustable height: 80mm
Base area: 200x152mm
Op. air pressure: 90-120psi

Excludes GST
\$389
Inc. GST \$427.90

20,000kg Capacity

INDUSTRIAL QUALITY

WELDED BASE



Air Actuated Bottle Jack Squat 20,000KG

PROBJ20TAS

Safe working capacity: 20,000kg
Working height: 185-330mm
Hydraulic lift: 80mm
Operating air pressure: 110-125psi
Adjustable height: 61mm
Air inlet fitting: 1/4"
Base: 230 x 150 x 30mm
Weight: 16kg

LATEST APPLIED TECHNOLOGIES
TQ Pro
Trusted by serious professionals

Professional Reputable Outstanding

Excludes GST
\$449
Inc. GST \$493.90

20,000kg Capacity

WELDED BASE



Air/Hydraulic Bottle Jack 30,000KG

BWBBJ30T INDUSTRIAL WORKSHOP EQUIPMENT

Safe working capacity: 30,000kg
Working height: 275 - 532mm
Hydraulic lift: 162mm
Adjustable height: 95mm
Base area: 229x180mm
Op. air pressure: 90-120psi

Excludes GST
\$499
Inc. GST \$548.90

INDUSTRIAL QUALITY

WELDED BASE



30,000kg Capacity

Air/Hydraulic Bottle Jack 30,000KG

PROBJ20TA

Safe working capacity: 30,000kg
Working height: 279.5-533mm
Hydraulic lift: 155mm
Op. air pressure: 110-125psi
Air inlet fitting: 1/4"
Base: 250 x 180 x 40mm
Weight: 29kg

LATEST APPLIED TECHNOLOGIES
TQ Pro
Trusted by serious professionals

Professional Reputable Outstanding

30,000kg Capacity

WELDED BASE



Air/Hydraulic Bottle Jack 35,000KG

BBJ35TA INDUSTRIAL WORKSHOP EQUIPMENT

Safe working capacity: 35,000kg
Working height: 264 - 414mm
Hydraulic lift: 150mm
Operating air pressure: 110-125psi
Air inlet fitting: 1/4"
Weight: 29kg

Excludes GST
\$520
Inc. GST \$572.00

35,000kg Capacity

INDUSTRIAL QUALITY



Excludes GST
\$589
Inc. GST \$647.90

Air/Hydraulic Bottle Jack 12,000KG

TQBJ12TA **TRADEQUIP**
The trusted brand in equipment

Safe working capacity: 12,000kg
Working height: 260-510mm
Adjustable screw: 80mm
Work pressure: 110-125psi
Hydraulic stroke: 170mm
Air inlet fitting: 1/4"

MADE FOR THE TRADE



12,000kg Capacity

Excludes GST
\$219
Inc. GST \$240.90

FEATURES

Compact powerful Air Turbo motor.
Versatile "quick connector" provides 'quick & easy air connection'.
Two piece pump handle.
Convenient welded carry handle.

Air/Hydraulic Squat Jack 20,000KG

TQBJ20TAS **TRADEQUIP**
The trusted brand in equipment

Safe working capacity: 20,000kg
Working height: 178-328mm
Adjustable screw: 63mm
Work pressure: 110-125psi
Hydraulic stroke: 87mm
Air inlet fitting: 1/4"

MADE FOR THE TRADE



20,000kg Capacity

Excludes GST
\$299
Inc. GST \$328.90



YouTube

Scan code for online product maintenance demonstration

Air/Hydraulic Bottle Jack 20,000KG

2026T **TRADEQUIP**
The trusted brand in equipment

Safe working capacity: 20,000kg
Working height: 265-510mm
Hydraulic lift: 170mm (265mm to 435mm)
Adjustable height: 75mm (max. height 510mm)
Base area: 224x134mm
Work pressure: 90-120psi
Weight: 16kg



20,000kg Capacity

Excludes GST
\$279
Inc. GST \$306.90

MADE FOR THE TRADE

FEATURES

Compact powerful Air Turbo motor.
Versatile "quick connector" provides 'quick & easy air connection'.
Two piece pump handle.
Convenient welded carry handle.

Air Actuated Super Low Profile Jack 20,000KG

2051T **TRADEQUIP**
The trusted brand in equipment

Safe working capacity: 20,000kg
Working height: 148-259mm
Screw extension height: 45mm
Operating air pressure: 100-145psi
Hydraulic stroke: 66mm
Air inlet fitting: 1/4"

MADE FOR THE TRADE



20,000kg Capacity

Excludes GST
\$369
Inc. GST \$405.90

FEATURES

Compact powerful Air Turbo motor.
Versatile "quick connector" provides 'quick & easy air connection'.
Chrome plated rams.
Convenient welded carry handle.



MADE FOR THE TRADE

Hydraulic Bottle Jacks

TRADEQUIP
The trusted brand in equipment

HEAVY DUTY One Piece Ergonomic Handle

from
Excludes GST
\$104
Inc. GST \$114.40



YouTube

Scan code for online product maintenance demonstration

FEATURES

Machined and polished cylinders with die-cut threads provide non-abrasive leak-free, durable performance. Fabricated from hard-cast steel with heat-treated critical stress areas.
Unique cross-type forged release valve ensures positive load control.
Overload protection Hydraulic system is protected from internal damage by a by-pass mechanism.
High quality glide-action pressure pump.
Supplied with 500mm pump handle.

Code	2012	2013	2014	2015	2016
Capacity	10,000kg	15,000kg	20,000kg	12,000kg	20,000kg
Hydraulic Lift	125mm	125mm	145mm	85mm	115mm
Adjustable Height	70mm	70mm	60mm	50mm	75mm
Min. Height	205mm	227mm	245mm	180mm	200mm
Max. Height	400mm	447mm	450mm	315mm	390mm
Base Area	124x124mm	148x136mm	167x156mm	157x134mm	167x156mm
Excl. GST	\$104	\$125	\$163	\$122	\$162
Incl. GST	\$114.40	\$137.50	\$179.30	\$134.20	\$178.20

Air Actuated Truck Jack 35,000KG

BTJ35TA **BORUM** INDUSTRIAL WORKSHOP EQUIPMENT

Safe working capacity: 35,000kg
Lift range: 255-633mm
Hydraulic lift: 155mm
Adjustable height: 123mm
Adaptors: 21, 61, 100mm
Handle length: 1110mm
Operating air pressure: 110-125psi
Chassis: 555L x 255H x 295Wmm

INDUSTRIAL QUALITY

Excludes GST
\$1169
Inc. GST \$1285.90

Includes Height Adaptors



LIFTS
35,000KG

FEATURES

Pro quality rugged steel construction.
Wear-resistant quality sealing O-rings.
Strong hydraulic pump & 3-position handle.
Temperature-resistant hydraulic oil.
Treated and polished piston and ram.
Built-in bypass hydraulic safety overload.
Compact design and Quick Lift ram.
Convenient & efficient height adaptors.
High quality lead-free paint.

Air Actuated Truck Jack 50,000KG

BTJ50TA **BORUM** INDUSTRIAL WORKSHOP EQUIPMENT

Safe working capacity: 50,000kg
Lift range: 287-650mm
Hydraulic lift: 153mm
Adjustable screw: 110mm
Adaptors: 20, 60, 100mm
Handle length: 1230mm
Operating air pressure: 110-125psi
Chassis: 525L x 288H x 325Wmm

INDUSTRIAL QUALITY

Excludes GST
\$1619
Inc. GST \$1780.90

LIFTS
50,000KG

Includes Height Adaptors



FEATURES

Pro quality rugged steel construction.
Wear-resistant quality sealing O-rings.
Strong hydraulic pump & 3-position handle.
Temperature-resistant hydraulic oil.
Treated and polished piston and ram.
Built-in bypass hydraulic safety overload.
Compact design and Quick Lift ram.
Convenient & efficient height adaptors.
High quality lead-free paint.

Air Actuated Jack 2 Stage 15,000/30,000KG

BTJ1530TA **BORUM** INDUSTRIAL WORKSHOP EQUIPMENT

1st stage: 30,000kg safe working capacity
2nd stage: 15,000kg safe working capacity
First stage hydraulic lift: 73mm
Second stage hydraulic lift: 66mm
Operating air pressure: 145-175psi
Height: 150-409mm
Adaptors: 45 and 75mm
Handle length: 1300mm
Chassis: 480 x 290 x 150mm

INDUSTRIAL QUALITY

Includes Height Adaptors



FEATURES

Double sealing function using XTP industry sealing.
Telescopic air actuation lift (air-hydraulic pump).
Long T-handle lets you easily position your jack under vehicle.
Self-returning lower & lift switch.
Internal and external cylinders hard chromed.
High manoeuvrability & deep reach under vehicles.
2 extension adaptors/saddle plates.
Large rubber wheels.

LIFTS
30,000KG

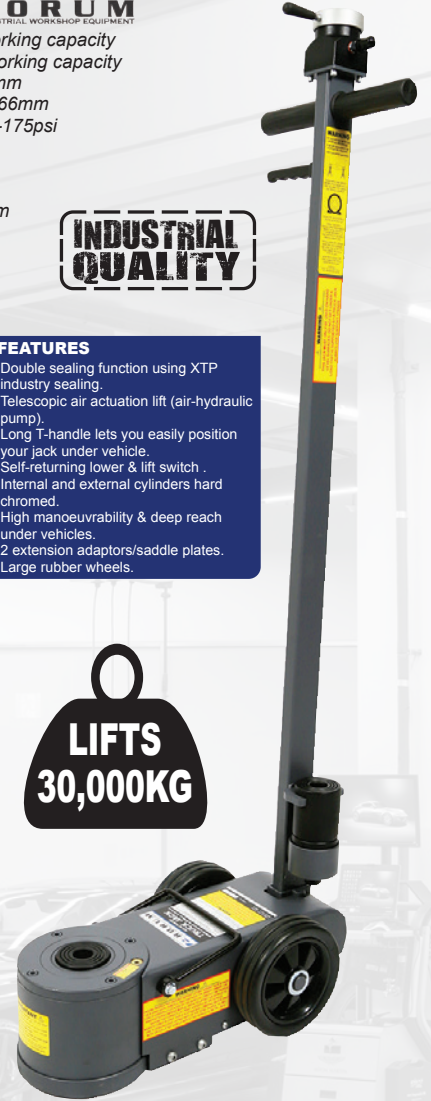

Excludes GST
\$2479
Inc. GST \$2726.90

Air Actuated Truck Jack 30,000KG

BTJ30TA **BORUM** INDUSTRIAL WORKSHOP EQUIPMENT

Safe working capacity: 30,000kg
Lift range: 360-772mm
Hydraulic lift: 267mm
Adaptors: 45 & 100mm
Handle length: 1370mm
Operating air pressure: 145-175psi
Chassis: 840L x 360H x 282Wmm

INDUSTRIAL QUALITY

NEW

Includes Height Adaptors

Excludes GST
\$4329
Inc. GST \$4761.90

FEATURES

XTP industry double sealing function using.
Telescopic air actuation lift.
Self-returning lowering and lifting switch.
Internal & external cylinders hard chromed
Long T-handle for high manoeuvrability & deep reach under vehicles.
Designed for extremely high axles.



LIFTS
30,000KG

Air Actuated Truck Jack 60,000KG

BTJ60TA **BORUM** INDUSTRIAL WORKSHOP EQUIPMENT

Safe working capacity: 60,000kg
Lift range: 420-1031mm
Hydraulic lift: 311mm
Adaptors: 100 & 200mm
Handle length: 1290mm
Operating air pressure: 145-175psi
Chassis: 910L x 420H x 300Wmm

Excludes GST
\$4999
Inc. GST \$5498.90

Includes Height Adaptors

INDUSTRIAL QUALITY

SUITS HIGH AXLES

FEATURES

Double sealing function using XTP industry sealing.
Telescopic air actuation lift.
Self-returning lowering and lifting switch.
Internal & external cylinders hard chromed
Long T-handle for high manoeuvrability & deep reach under vehicles.
Designed for extremely high axles.



LIFTS
60,000KG

TOO NEW TO PHOTOGRAPH. VISIT WWW.TQBBrands.COM.AU FOR UPDATED IMAGES AND MORE SPECS.

Air Actuated 2 Stage Truck Jack 10,000/25,000KG

BTJ1025TA **BORUM**
INDUSTRIAL WORKSHOP EQUIPMENT

Stage 1: 25,000kg safe working capacity
Stage 2: 10,000kg safe working capacity
Lift range: 185-497mm
Hydraulic lift: Stage1: 97mm, Stage2: 95mm
Adaptors: 45, 75mm
Handle length: 1380mm
Operating air pressure: 145-175psi
Chassis: 770L x 282H x 185Wmm

LIFTS
25,000KG

INDUSTRIAL QUALITY

DEEP REACH

Excludes GST
\$3182
Inc. GST \$3500.20

Includes Height Adaptors

FEATURES

Double sealing function - XTP industry sealing.
Telescopic air actuation lift.
Self-returning lowering and lifting switch.
Internal & external cylinders hard chromed
Long T-handle for high manoeuvrability & deep reach under vehicles.

Air Actuated 2 Stage Truck Jack 25,000/50,000KG

BTJ2550TA **BORUM**
INDUSTRIAL WORKSHOP EQUIPMENT

Stage 1: 50,000kg safe working capacity
Stage 2: 25,000kg safe working capacity
Lift range: 215-564mm
Hydraulic lift: Stage1: 115mm, Stage2: 114mm
Adaptors: 45, 75mm
Handle length: 1380mm
Operating air pressure: 145-175psi
Chassis: 805L x 282H x 215Wmm

LIFTS
50,000KG

INDUSTRIAL QUALITY

Excludes GST
\$3699
Inc. GST \$4068.90

Includes Height Adaptors

FEATURES

Double sealing function - XTP industry sealing.
Telescopic air actuation lift.
Self-returning lowering and lifting switch.
Internal & external cylinders hard chromed
Long T-handle for high manoeuvrability & deep reach under vehicles.

Air Actuated 3 Stage Truck Jack 10,000/25,000/50,000KG

BTJ102550TA **BORUM**
INDUSTRIAL WORKSHOP EQUIPMENT

Safe working capacity: Stage1: 10,000kg
Stage2: 25,000kg, Stage3: 50,000kg
Lift range: 160-472mm
Hydraulic lift: Stage1: 62mm
Stage2: 61mm, Stage3: 69mm
Adaptors: 45, 75mm
Handle length: 1380mm
Operating air pressure: 145-175psi
Chassis: 825L x 282H x 160Wmm

LIFTS
50,000KG

INDUSTRIAL QUALITY

Includes Height Adaptors

DEEP REACH
LOWER PROFILE

FEATURES

Double sealing function using XTP industry sealing.
Telescopic air actuation lift.
Self-returning lowering and lifting switch.
Internal & external cylinders hard chromed
Long T-handle for high manoeuvrability & deep reach under vehicles.

Excludes GST
\$3669
Inc. GST \$4035.90

Air Actuated 3 Stage Truck Jack 20,000/40,000/60,000KG

BTJ204060TA **BORUM**
INDUSTRIAL WORKSHOP EQUIPMENT

First stage: 60,000kg safe working capacity
Second stage: 40,000kg safe working capacity
Third stage: 20,000kg safe working capacity
First stage hydraulic lift: 57mm
Second stage hydraulic lift: 59mm
Third stage hydraulic lift: 61mm
Height: 150-447mm
Adaptors: 45 and 75mm
Operating air pressure: 145-175psi
Handle length: 1380mm
Chassis: 875 x 295 x 150mm

LIFTS
60,000KG

INDUSTRIAL QUALITY

Includes Height Adaptors

SUPER DEEP SUPER LOW

Excludes GST
\$4099
Inc. GST \$4508.90

FEATURES

Double sealing function using XTP industry sealing.
Telescopic air actuation lift (air-hydraulic pump).
Long T-handle lets you easily position your jack under vehicle.
Self-returning lowering and lifting switch.
Internal and external cylinders hard chromed .
High manoeuvrability & deep reach under vehicles.
2 extension adaptors / saddle plates.
Large rubber wheels.

Air Actuated 2 Stage Truck Jack 50,000/80,000KG

BTJ5080TA **BORUM**
INDUSTRIAL WORKSHOP EQUIPMENT

First stage: 80,000kg safe working capacity
Second stage: 50,000kg safe working capacity
First stage hydraulic lift: 111mm
Second stage hydraulic lift: 102mm
Height: 230-563mm
Adaptors: 45 and 75mm
Operating air pressure: 145-175psi
Handle length: 1300mm
Chassis: 930 x 340 x 230mm

LIFTS
80,000KG

INDUSTRIAL QUALITY

SUPER DEEP SUPER HIGH LIFT SUPER HIGH CAPACITY

Excludes GST
\$4599
Inc. GST \$5058.90

Includes Height Adaptors

FEATURES

Double sealing function using XTP industry sealing.
Telescopic air actuation lift (air-hydraulic pump).
Long T-handle lets you easily position your jack under vehicle.
Self-returning lowering and lifting switch.
Internal and external cylinders hard chromed .
High manoeuvrability & deep reach under vehicles.
2 extension adaptors / saddle plates.
Large rubber wheels.

Air Actuated Truck Jack 22,000KG

B2003T **BORUM**
INDUSTRIAL WORKSHOP EQUIPMENT

Safe working capacity: 22,000kg
Lift range: 210-525mm
Hydraulic lift: 120mm
Adjustable height: 105mm
Handle length: 1075mm
Air supply: 100-120psi
Wheel diameter: 175mm
Adaptors: 20, 50, 100mm
Chassis: 500L x 215H x 320Wmm

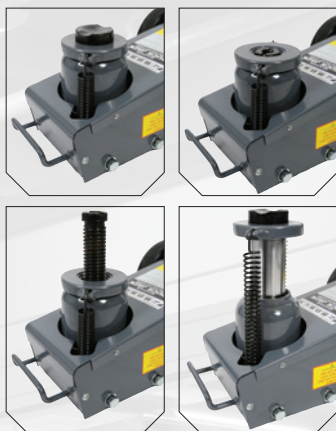

FEATURES

Solid heavy duty construction.
Advanced technology sealing rings.
Fast motion super duty air pump.
Temperature-resistant hydraulic oil.
Treated and polished piston and ram.
Built-in bypass hydraulic safety overload system.
Compact design easily fits dual tandem axles.
Convenient & efficient height adaptors.
3-position pumping handle.
High quality lead-free paint is oil, grease and dirt-resistant finish for easy cleanup.

INDUSTRIAL QUALITY

Excludes GST
\$1029
Inc. GST \$1132.90

HIGH FLOW AIR PUMP

Includes Height Adaptors



LIFTS 22,000KG

Air Actuated Truck Jack 22,000KG

2004T **TRADEQUIP**
The trusted brand in equipment

Safe working capacity: 22,000kg
Lift range: 225-552mm
Hydraulic lift: 124mm
Adjustable height: 103mm
Chassis: 560L x 230H x 320Wmm
Adaptors: 21, 60, 100mm
Handle length: 1160mm
Wheel diameter: 200mm

MADE FOR THE TRADE



Includes Height Adaptors



LIFTS 22,000KG

Excludes GST
\$819
Inc. GST \$900.90

FEATURES

Trade quality rugged steel construction.
Wear-resistant quality sealing O-rings.
Strong hydraulic pump.
Temperature-resistant hydraulic oil.
Treated and polished piston and Quick lift ram.
Built-in bypass hydraulic safety overload system.
Compact design easily fits dual tandem axles.
Convenient & efficient height adaptors.
3-position pumping handle.
High quality lead-free paint is oil, grease and dirt-resistant finish for easy cleanup.

Air Jack Support Stand 10,000KG

BSJ10T **BORUM**
INDUSTRIAL WORKSHOP EQUIPMENT

Safe working capacity: 10,000kg
Height: Min. 444mm - Max. 1298mm
Hydraulic lift: 292mm
Base diameter: 339mm
Rated air pressure capacity: 200psi
Weight: 91kg

Excludes GST
\$1349
Inc. GST \$1483.90

FEATURES

The BORUM Industrial AIR JACK/SUPPORT STAND 10,000KG is a reinforced pin style jack and stand with industrial quality design and support bracing system to sustain heavy loads up to 10,000kg. Adjusts to match the job with a 444mm minimum height, 292mm of hydraulic lift and up to 1298mm maximum height using the extension tube!! Featuring Heavy-Duty Industrial design, this tough air jack/support stand is ideal for truck, bus, farm, earthmoving equipment and fleet vehicle maintenance workshop use.



INDUSTRIAL QUALITY

Air Actuated Truck Jack 20,000KG

PROTRJA20T **TQ PRO**
LATEST APPLIED TECHNOLOGIES
Trusted by serious professionals

Safe working capacity: 20,000kg
Working height: 215-541mm
Hydraulic Lift: 141mm
Adjustable screw: 85mm
Adaptors: 20, 50, 100mm
Handle length: 1335mm
Operating air pressure: 145-175psi
Chassis: 520L x 215H x 258Wmm

Professional Reputable Outstanding



LIFTS 20,000KG

Excludes GST
\$1349
Inc. GST \$1483.90

FEATURES

Double sealing using XTP industry sealing.
Telescopic air actuation lift (air-hydraulic pump).
Long T-handle lets you easily position your jack under vehicle.
Self-returning lowering and lifting switch.
Internal and external cylinders hard chromed.
High manoeuvrability & deep reach.
3 extension adaptors/saddle plates.

SELF-RETURNING LOWERING & LIFTING SWITCH

Portable Truck Ramps

BTR20TP **BORUM**
INDUSTRIAL WORKSHOP EQUIPMENT

Safe working load: 20,000kg per pair
Frame: 1160L x 463W x 242Hmm
Max. tyre width: 393mm

pair

Excludes GST
\$1710
Inc. GST \$1881.00

INDUSTRIAL QUALITY

Suitable for Buses and Trucks

FEATURES

Long retractable T-handle for easy positioning.
"NON-SKID BASE" - 4 ply pads of rubber grips are bolted and glued to the 6mm steel floor plates and they will not skid ahead of the wheels.
Replaces need for a pit or hoist, and at a fraction of the cost and floor space.





Truck Jack Stands **BORUM**
INDUSTRIAL WORKSHOP EQUIPMENT

SOLD INDIVIDUALLY

Code	15TJSSHORT	15TJS
Load limit	15,000kg	15,000kg
Height	446 - 631mm	645-1077mm
Base Area	300x300mm	460x460mm
Excl. GST	\$425	\$519
Incl. GST	\$467.50	\$570.90

Code	25TJSSHORT	25TJS
Load limit	25,000kg	25,000kg
Height	415 - 539mm	680-968mm
Base Area	300x300mm	460x460mm
Excl. GST	\$529	\$599
Incl. GST	\$581.90	\$658.90

INDUSTRIAL QUALITY

FEATURES

Manufactured from high-grade steel and built to exacting standards for quality and durability. Lead-free paint finish is oil, grease and dirt-resistant for easy cleanup. High strength locking pin. Controlled pin holes for easy height adjustments. Turned post slide for easy quick adjustments. Heavy-gauge steel Gusseted uprights prevent distortion or twisting. Rugged base provides plenty of stability. Conveniently located carry handle. Sold individually. (not in pairs)



from
Excludes GST
\$425
Inc. GST \$467.50

Auxiliary Stand 7,000KG

BAUXS7T **BORUM**
INDUSTRIAL WORKSHOP EQUIPMENT

Safe working capacity: 7,000kg
Working height: 1295-1905mm
Adjustable pin heights:
8 (75mm increments)
Base: 300x300x300mm
Weight: 65kg

FEATURES

Heavy duty design and support bracing system to sustain heavy vehicle loads. Manufactured from high-grade steel and built to exacting standards for quality and durability. Fitted with spring loaded castor wheels to ensure easy movement around the workshop. Fitted with spring loaded support beam. Lead-free paint finish is applied after a thorough chemical wash to ensure a long-lasting finish and to help prevent rust. Paint is oil, grease and dirt-resistant for easy cleanup. High strength locking pin. Controlled pin holes for easy height adjustments. Turned post slide for easy quick adjustments.

INDUSTRIAL QUALITY

7,000kg Capacity

Max. height 1905mm



Spring loaded castor wheels

Excludes GST
\$1499
Inc. GST \$1648.90

Support Stand 10,000KG

10TSS **BORUM**
INDUSTRIAL WORKSHOP EQUIPMENT

Safe working capacity: 10,000kg
Working height: 720-1190mm
Adjustable pin heights: 10
Saddle dimensions: 150x80mm
Base: 406 x 556mm
Weight: 23.5kg

FEATURES

Stable 4 legged stability. Lead-free paint is oil, grease and dirt-resistant for easy cleanup. High strength locking pin & controlled pin holes for easy height adjustments. Turned post slide for easy adjustment.

***10TSS/10TSSSHORT SOLD INDIVIDUALLY**

INDUSTRIAL QUALITY

10,000kg Capacity

Max. height 1190mm



Excludes GST
\$399
Inc. GST \$438.90

Support Stand SHORT 10,000KG

10TSSSHORT **BORUM**
INDUSTRIAL WORKSHOP EQUIPMENT

Safe working capacity: 10,000kg
Working height: 480-780mm
Adjustable pin heights: 6
Saddle dimensions: 150x80mm
Base: 310 x 310mm
Weight: 18kg

Excludes GST
\$359
Inc. GST \$394.90

Jumbo Spanner Set 10 Piece Imperial

B10PJSI **BORUM**
INDUSTRIAL WORKSHOP EQUIPMENT

10 Imperial Sizes:
1 5/16", 1 3/8", 1 7/16", 1 1/2", 1 5/8",
1 11/16", 1 3/4", 1 13/16", 1 7/8" 2"
Wallet rolled out: 830 x 690 x 30mm
Wallet rolled up: 150 x 690 x 130mm
Weight: 14kg

Excludes GST
\$255
Inc. GST \$280.50

INDUSTRIAL QUALITY

Jumbo Spanner Set 10 Piece Metric

B10PJS **BORUM**
INDUSTRIAL WORKSHOP EQUIPMENT

10 Metric Sizes:
34mm, 36mm, 38mm, 41mm, 42mm,
44mm, 45mm, 46mm, 48mm & 50mm
Wallet rolled out: 830 x 690 x 30mm
Wallet rolled up: 150 x 690 x 130mm
Weight: 14kg

Excludes GST
\$255
Inc. GST \$280.50



Workshop Press 20,000KG

1061T **TRADEQUIP**
the trusted brand in equipment

Safe working capacity: 20,000kg
Working range: 60-773mm
Overall height: 1503mm
Overall width: 705mm
Overall depth: 660mm
Bed width: 504mm
Bed gap: 103mm
Bed inside: 285 x 103mm
Press head diameter: 40mm
Press head length: 68mm
Jacking handle: 694mm
Piston ram stroke: 160mm
Weight: 82kg



Excludes GST
\$569
Inc. GST \$625.90

FEATURES

High-grade Channel Steel. Hydraulics are powered with a high quality oil. Integrated overload protection valve keeps from overloading the system. Lead-free paint finish is oil, grease and dirt-resistant for easy cleanup and to help prevent rust.

Workshop Press 30,000KG

1062T **TRADEQUIP**
the trusted brand in equipment

Safe working capacity: 30,000kg
Working range: 45-705mm
Overall height: 1605mm
Overall width: 745mm
Overall depth: 660mm
Bed width: 480mm
Bed gap: 124mm
Bed inside: 254 x 124mm
Press head diameter: 50mm
Press head length: 68mm
Jacking handle: 694mm
Piston ram stroke: 163mm
Weight: 113kg



Excludes GST
\$929
Inc. GST \$1021.90

FEATURES

High-grade Channel Steel. Hydraulics are powered with a high quality oil. Integrated overload protection valve keeps from overloading the system. Lead-free paint finish is oil, grease and dirt-resistant for easy cleanup and to help prevent rust.

Hydraulic Workshop Press 20,000KG

1063T **TRADEQUIP**
the trusted brand in equipment

Safe working capacity: 20,000kg
Working range: 43-882mm
Overall height: 1795mm
Overall width: 780mm
Overall depth: 690mm
Bed width: 505mm
Bed gap: 105mm
Bed Inside: 358 x 105mm
Press head cap diam: 45mm
Press head cap length: 17mm
Ram lateral adjustment: 180mm
Piston ram stroke: 185mm
Weight: 90kg

FEATURES

High-grade Channel Steel. 100mm pressure gauge. High quality large diameter hydraulic steel cylinder unit. Hydraulics are powered with a high quality oil. Integrated overload protection valve keeps from overloading the system. Lead-free paint finish is oil, grease and dirt-resistant for easy cleanup and to help prevent rust.

Lateral Ram Adjustment



Excludes GST
\$899
Inc. GST \$988.90

Hydraulic Workshop Press 30,000KG

1064T **TRADEQUIP**
the trusted brand in equipment

Safe working capacity: 30,000kg
Working range: 50-1030mm
Overall height: 1950mm
Overall width: 830mm
Overall depth: 660mm
Bed width: 455mm
Bed gap: 154mm
Bed inside: 230 x 154mm
Press head diameter: 56mm
Load cap length: 17mm
Jacking Handle: 639mm
Ram lateral adjustment: 70mm
Piston ram stroke: 170mm
Weight: 138kg

FEATURES

High-grade Channel Steel. 100mm pressure gauge. High quality large diameter hydraulic steel cylinder unit. Hydraulics are powered with a high quality oil. Integrated overload protection valve keeps from overloading the system. Lead-free paint finish is oil, grease and dirt-resistant for easy cleanup and to help prevent rust.

Lateral Ram Adjustment



Excludes GST
\$1299
Inc. GST \$1428.90

*Additional Freight Rates may apply

SHOP PRESSES

Hydraulic Workshop Press 45,000KG WIDE

2036T **TRADEQUIP**
The trusted brand in equipment

Safe working capacity: 45,000kg
Working range: 159-859mm
Bed outside: 359mm
Bed inside: 195mm
Bed width: 826mm
Piston ram stroke: 190mm
Ram diameter: 90mm
1707H x 1420W x 826Dmm
Bed height settings: 6
Weight: 296kg

MADE FOR THE TRADE



6 HEIGHT SETTINGS

FEATURES

High-grade steel frame.
100mm pressure gauge.
Bed winch for easy raise and lower adjustment.
Lead-free paint finish is oil, grease and dirt-resistant.
Hand winch for fast adjustment.

Excludes GST
\$3299
Inc. GST \$3628.90

45,000kg Capacity

BONUS
12 MONTH PARTS ONLY WARRANTY ON HYDRAULIC RAM & HYDRAULIC PUMP IN ADDITION TO STANDARD 12 MONTH WARRANTY***

Air/Hydraulic Workshop Press 45,000KG WIDE

2038T **TRADEQUIP**
The trusted brand in equipment

Safe working capacity: 45,000kg
Working range: 159-859mm
Bed outside: 359mm
Bed inside: 195mm
Bed width: 826mm
Piston ram stroke: 190mm
Ram diameter: 90mm
Op. air pressure: 110-125 psi
1707H x 1420W x 800Dmm
Bed height settings: 6
Weight: 301kg
AIR OPERATED

6 HEIGHT SETTINGS



FEATURES

High-grade steel frame.
2 speed pump. 100mm pressure gauge.
Bed winch for easy raise and lower adjustment.
Paint is oil, grease and dirt-resistant for easy cleanup.
High quality large diameter hydraulic steel cylinder unit.
Piston-ram is treated, polished. Includes hand winch.
Integrated overload protection valve prevents overloading.
Extra-long handle included for easy pumping force.
Double spring ram return for fast ram retraction.

MADE FOR THE TRADE

Excludes GST
\$3499
Inc. GST \$3848.90

BONUS
12 MONTH PARTS ONLY WARRANTY ON HYDRAULIC RAM & HYDRAULIC PUMP IN ADDITION TO STANDARD 12 MONTH WARRANTY***

45,000kg Capacity

Hydraulic Workshop Press 50,000KG

2048T **TRADEQUIP**
The trusted brand in equipment

Safe working capacity: 50,000kg
Working range: 137-837mm
Bed outside: 356mm
Bed inside: 210mm
Bed width: 713mm
Bed internal: 390 x 200mm
Piston ram stroke: 190mm

Ram diameter: 95mm
Op. air pressure: 110-125 psi
1700H x 1290W x 745Dmm
Bed height settings: 6
Weight: 271kg

MADE FOR THE TRADE



6 HEIGHT SETTINGS

FEATURES

Heavy-duty high-grade steel frame.
Hand operated air trigger ram travel control.
100mm pressure gauge.
Polished pneumatic aluminium air motor.
Bed winch for easy raise and lower adjustment.
Lead-free paint finish helps prevent rust & is oil, grease and dirt-resistant.
High quality large diameter hydraulic unit.
Hand winch for fast height adjustments.

Workshop Press Adaptor Kit

BPAK **BORUM**
INDUSTRIAL WORKSHOP EQUIPMENT

Includes 8 different sized pins (mandrels) ranging from 2,000kg to 20,000kg capacity, a pin holder, a storage shelf along with a mounting kit, and a pin plate with the weight capacity shown for each pin.
This very handy set of eight steel mandrels, adaptor and press plate expands the uses of your workshop press for a wider range of applications involving different sized work pieces.

Excludes GST
\$179
Inc. GST \$196.90

INDUSTRIAL QUALITY



Mandrel
Length x Diameter
50mm x 10mm
60mm x 12mm
60mm x 16mm
85mm x 18mm
85mm x 20mm
85mm x 22mm
15mm x 25mm
110mm x 30mm

***UNLESS STATED OTHERWISE, ALL TQB BRANDS PRODUCTS, EXCLUDING CONSUMABLES, COME WITH A 12 MONTH COMMERCIAL USE WARRANTY AGAINST MANUFACTURING DEFECTS. THE BONUS 12 MONTH WARRANTY OFFERED EXCLUSIVELY IN THIS PROMOTIONAL PERIOD APPLIES ONLY TO THE HYDRAULIC RAM AND HYDRAULIC PUMP FOR "BONUS" MARKED PRODUCTS. THE ADDITIONAL 12 MONTHS DOES NOT INCLUDE INSTALLATION/REMOVAL LABOUR OR FREIGHT FOR THE COMPONENT.

Air/Hydraulic Workshop Press 30,000KG

PROSHPR30TA

Safe working capacity: 30,000kg
Working range: 25-850mm
Screw adjustment: 75mm
Bed outside: 164mm
Bed inside: 148mm
Bed width: 600mm
Ram diameter: 58mm
Bed height settings: 6
1800H x 770W x 505Dmm
Weight: 163kg

SAFETY BARRIER AVAILABLE SEPARATELY

TQPro LATEST APPLIED TECHNOLOGIES
Trusted by serious professionals
Professional Reputable Outstanding

30,000kg Capacity

TQPro LATEST APPLIED TECHNOLOGIES
Trusted by serious professionals

- ✓ Mandrel Kit Included
- ✓ Long Pump Handle
- ✓ Premium Bed Blocks
- ✓ Winch Adjustable Bed
- ✓ Premium Hydraulic System
- ✓ Premium Paint Finish
- ✓ Precision Lateral Ram Adjustment
- ✓ Premium Grade Steel Construction
- ✓ Designed for maximum strength, reliability and durability
- ✓ Foot Pedal Air/Hydraulic Operation

YouTube
Scan code for TQPro Presses online product demonstration



Air/Hydraulic Workshop Press 50,000KG

PROSHPR50TA

Safe working capacity: 50,000kg
Working range: 80-780mm
Screw adjustment: 75mm
Bed inside: 200mm
Bed outside: 220mm
Bed width: 750mm
Ram diameter: 68mm
Bed height settings: 6
1900H x 930W x 535Dmm
Weight: 243kg

SAFETY BARRIER AVAILABLE SEPARATELY

TQPro LATEST APPLIED TECHNOLOGIES
Trusted by serious professionals
Professional Reputable Outstanding



Hydraulic Workshop Press 20,000KG

BHSP20T **BORUM** INDUSTRIAL WORKSHOP EQUIPMENT

Safe working capacity: 20,000kg
Working range: 38-918mm
Bed outside: 172mm
Bed inside: 152mm
Bed width: 510mm
Piston ram stroke: 185mm
Bed height settings: 8
Ram diameter: 72mm
1626H x 755W x 560Dmm
Weight: 115kg

8 HEIGHT SETTINGS

INDUSTRIAL QUALITY

FEATURES
Heavy-duty high-grade steel H-frame. Integrated overload protection valve. Foot & Hand operated pump. 100mm pressure gauge. STEEL SAFETY MESH BARRIER. Lead free paint finish is oil, grease and dirt-resistant for easy cleanup. Piston-ram is fitted with backup ring, preventing bypass oil drift. High quality hydraulic oil offers better corrosion resistance and flexibility. Pair of bed plates included.

Excludes GST
\$2049
Inc. GST \$2253.90



20,000kg Capacity

BONUS
12 MONTH PARTS ONLY WARRANTY ON HYDRAULIC RAM & HYDRAULIC PUMP IN ADDITION TO STANDARD 12 MONTH WARRANTY***

Hydraulic Workshop Press 30,000KG

BHSP30T **BORUM** INDUSTRIAL WORKSHOP EQUIPMENT

Safe working capacity: 30,000kg
Working range: 151-1031mm
Bed outside: 184mm
Bed inside: 164mm
Bed width: 535mm
Piston ram stroke: 150mm
Bed height settings: 8
Ram diameter: 80mm
1830H x 1000W x 700Dmm
Weight: 167kg

8 HEIGHT SETTINGS

INDUSTRIAL QUALITY

FEATURES
Heavy-duty high-grade steel H-frame. Integrated overload protection valve. Foot & Hand operated pump. 100mm pressure gauge. STEEL SAFETY MESH BARRIER. Lead free paint finish is oil, grease and dirt-resistant for easy cleanup. Piston-ram is fitted with backup ring, preventing bypass oil drift. High quality hydraulic oil offers better corrosion resistance and flexibility. Pair of bed plates included.

Excludes GST
\$2899
Inc. GST \$3188.90



30,000kg Capacity

BONUS
12 MONTH PARTS ONLY WARRANTY ON HYDRAULIC RAM & HYDRAULIC PUMP IN ADDITION TO STANDARD 12 MONTH WARRANTY***

*Additional Freight Rates may apply

SHOP PRESSES

Air/Hydraulic Workshop Press 75,000KG

BSP75TA **BORUM**
INDUSTRIAL WORKSHOP EQUIPMENT

Safe working capacity: 75,000kg
Working range: 170-884mm
Overall height: 1925mm
Overall width: 1340mm
Overall depth: 800mm
Bed width: 800mm
Bed surface depth: 279mm

Piston ram stroke: 250mm
Ram diameter: 125mm
Width between side posts: 217mm
Bed height settings: 8
Operating air pressure: 110-125psi
Air inlet: 1/4"NPT
Weight: 451kg

8 HEIGHT SETTINGS

INDUSTRIAL QUALITY

Power to safely remove & install bearings, gears, U-joints, bushings, ball joints and pulleys with precision and versatility!

75,000kg Capacity



BONUS
12 MONTH PARTS ONLY WARRANTY ON HYDRAULIC RAM & HYDRAULIC PUMP IN ADDITION TO STANDARD 12 MONTH WARRANTY***

Excludes GST
\$7999
Inc. GST \$8798.90



Air/Hydraulic Workshop Press 100,000KG

BSP100TA **BORUM**
INDUSTRIAL WORKSHOP EQUIPMENT

Safe working capacity: 100,000kg
Working range: 113-813mm
Overall height: 1848mm
Overall width: 1250mm
Overall depth: 990mm
Bed width: 787mm
Bed surface depth: 342mm

Piston ram stroke: 300mm
Ram diameter: 140mm
Width between side posts: 268mm
Bed height settings: 6
Operating air pressure: 110-125psi
Air inlet: 1/4"NPT
Weight: 652kg

6 HEIGHT SETTINGS

INDUSTRIAL QUALITY

Ideal for straightening, stamping, bending and pressing any component that is difficult to handle.

100,000kg Capacity



BONUS
12 MONTH PARTS ONLY WARRANTY ON HYDRAULIC RAM & HYDRAULIC PUMP IN ADDITION TO STANDARD 12 MONTH WARRANTY***

Excludes GST
\$11,499
Inc. GST \$12,648.90

FEATURES

- Heavy-duty H-frame constructed of high-grade steel and built to exacting standards for quality and durability.
- Foot operated air trigger ram travel control. • 100mm pressure gauge. • Extra tall working range for versatility. • Pair of bed plates included
- Table winch system lowers or raises the bed. • Integrated overload protection valve keeps from overloading the system.
- High quality large diameter hydraulic steel cylinder unit results in lower oil pressure needed to raise the load, helping to reduce wear and extend service life.
- Piston-ram is treated and polished and fitted with backup ring, preventing load from falling slowly or bypassing oil drift.
- Hydraulics are powered with a high quality oil, which offers better corrosion resistance and high/low temperature flexibility, allowing the unit to operate at temperatures.
- Lead-free paint finish is applied after a thorough chemical wash to ensure a long-lasting finish and to help prevent rust. Oil, grease and dirt-resistant for easy clean up.

***UNLESS STATED OTHERWISE, ALL TQB BRANDS PRODUCTS, EXCLUDING CONSUMABLES, COME WITH A 12 MONTH COMMERCIAL USE WARRANTY AGAINST MANUFACTURING DEFECTS. THE BONUS 12 MONTH WARRANTY OFFERED EXCLUSIVELY IN THIS PROMOTIONAL PERIOD APPLIES ONLY TO THE HYDRAULIC RAM AND HYDRAULIC PUMP FOR "BONUS" MARKED PRODUCTS. THE ADDITIONAL 12 MONTHS DOES NOT INCLUDE INSTALLATION/REMOVAL LABOUR OR FREIGHT FOR THE COMPONENT.

Polycarbonate TQB Shop Press Safety Barrier

TRADEQUIP
The trusted brand in equipment

SUIT TQB BRANDS PRESSES ONLY

MADE FOR THE TRADE

Multiple Height Settings

NEW

SGUARD-1
PRESS GUARD
POLY CARBONATE
SUIT 1061/1062/1063T

Excludes GST
\$192
Inc. GST \$211.20

SGUARD-3
PRESS GUARD
POLY CARBONATE
SUIT BSP75TA

Excludes GST
\$259
Inc. GST \$273.90

SGUARD-2
PRESS GUARD
POLY CARBONATE
SUIT 1064T

Excludes GST
\$219
Inc. GST \$240.90

SGUARD-4
PRESS GUARD
POLY CARBONATE
SUIT 2048T/2038T/
2036T/BSP100TA

Excludes GST
\$315
Inc. GST \$346.50

*** AVAILABLE IN FOUR DIFFERENT SIZES ***



*DOES NOT INCLUDE PRESS AND ACCESSORIES SHOWN

Master Press & Pull Set 28 Piece

9028T **TRADEQUIP**
The trusted brand in equipment

4 x Step plates: 74, 76, 78, 80mm
4 x Pulling spindles with thrust bearings
20 x Press sleeves: 44 x 43; 46 x 36;
48 x 38; 50 x 40; 52 x 42; 54 x 44; 56 x 46;
58 x 48; 60 x 50; 62 x 52; 64 x 54; 66 x 56;
68 x 58; 70 x 60; 72 x 62; 74 x 64; 76 x 66;
78 x 68; 80 x 70; 82 x 72mm
Heat-treated forged carbon steel
Sturdy Blow Mould Case



Excludes GST
\$429
Inc. GST \$471.90

MADE FOR THE TRADE

FWD Wheel Bearing Kit 23 Piece

9029T **TRADEQUIP**
The trusted brand in equipment

Hub screw length: 207mm
Hub screw drive: 32; 38mm
Sleeve external: 76.5 x 65; 86 x 77;
91 x 81.5; 102 x 92mm
Drift sizes: 50; 55; 59; 63; 66.5;
70; 71.5; 73; 73.5; 75; 77.5; 81.4;
83.3; 86; 88.4; 102mm
Heat-treated forged carbon steel
Sturdy Blow Mould Case



Excludes GST
\$229
Inc. GST \$251.90

MADE FOR THE TRADE

Universal Press & Pull Sleeve Kit 26 Piece

9024T **TRADEQUIP**
The trusted brand in equipment

4 Beams
3 1/2" Sleeves
20 Sleeves
11 pieces (GOLD)
9 pieces (SILVER)



Excludes GST
\$368
Inc. GST \$404.80

MADE FOR THE TRADE

For removal and installation of bushes, bearings and seals, races, sprockets and pulleys on cars, trucks, off-road construction equipment and machinery

Hydraulic Gear Puller 23 Piece

9023T **TRADEQUIP**
The trusted brand in equipment

Capacity: 10,000kg
Bearing Separator: 20-105mm
Twin/triple head, beam and legs to build: 100, 150 and 200mm
Two and three leg hydraulic pullers with separator capacity: 75-105mm
Size: 355L x 195W x 150Hmm



Pulls bearings, timing gears, steering wheels and pulleys on most cars and light trucks

Excludes GST
\$349
Inc. GST \$383.90

MADE FOR THE TRADE

Universal Press Support Block 30,000KG

9025T **TRADEQUIP**
The trusted brand in equipment

Base block: 250 x 200 x 40mm
Height adaptor block: 200x70x40mm
Made from Billet aluminium

For use with a hydraulic shop press for workpieces with a complicated shape to allow bearings to be pressed in or out accurately.

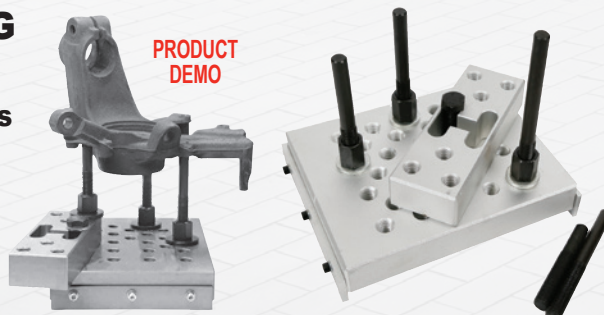

Excludes GST
\$338
Inc. GST \$371.80

MADE FOR THE TRADE

ALL BORUM DRILL PRESSES FEATURE

Flexible worklight. Engineering style work table.
Oversize micro-switch activated safety guard.
Low-noise belt drive with cast iron balanced pulleys.
Safety ON-OFF switch fitted with a dust cover and positive action push buttons plus a large (Red) self locking "Emergency Stop" hinge cover.
Precision spindle bearing for long life & high accuracy.
Table control via hand crank and gear rack with high load capacity.
Long quill stroke, easy to adjust depth stop at the capstan handle.
Thick-walled, precision-ground column for extra rigidity.
Powerful long-life commercial drive motor provides high reliability.
Ground set-up areas on table and base plate.
Solid rotating work table with diagonal clamping slots.

**The same reliable
'Heavy Duty Industrial
Quality Drill Presses'
since we started
manufacturing them in
1984... but with
the benefit of some
21st Century features**



3/4HP Pedestal Drill Press 16 Speed

CH16NFT **BORUM**
INDUSTRIAL WORKSHOP EQUIPMENT

Motor: 240Volt 3/4HP
Number of speeds: 16
Spindle taper: MT2
Spindle speeds: 162-3000rpm
Max. drilling capacity: 16mm
Max. spindle stroke: 78mm
Max. distance spindle to table: 7810mm
Max. distance spindle to base: 1219mm
Chuck: 16mm
Swing: 535
Size of table: 473x410mm
Diameter of column: 73mm
Size of base: 450x265mm
Overall height: 1588mm

**INDUSTRIAL
QUALITY**

**Max.
DRILL
CAPACITY
16mm**

Excludes GST
\$1059
Inc. GST \$1164.90

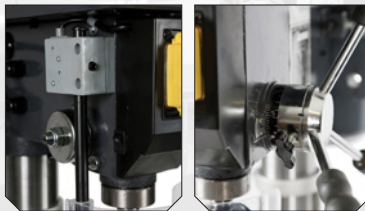

Overall height: 1588mm

1HP Pedestal Drill Press 16 Speed

CH18FT **BORUM**
INDUSTRIAL WORKSHOP EQUIPMENT

Motor: 240Volt 1HP
Number of speeds: 16
Spindle taper: MT2
Spindle speeds: 200-3160rpm
Max. drilling capacity: 20mm
Max. spindle stroke: 82mm
Max. distance spindle to table: 775mm
Max. distance spindle to base: 1270mm
Chuck: 16mm
Swing: 430mm
Table diameter: 350mm
Diameter of column: 80mm
Size of base: 460x270mm
Overall height: 1625mm

**Max.
DRILL
CAPACITY
20mm**

Excludes GST
\$1529
Inc. GST \$1681.90

**INDUSTRIAL
QUALITY**

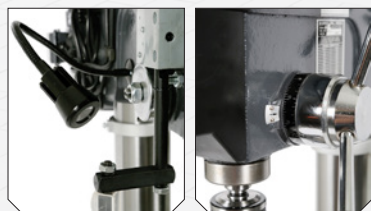

Overall height: 1625mm

2HP Pedestal Drill Press 12 Speed

CH30T **BORUM**
INDUSTRIAL WORKSHOP EQUIPMENT

Motor: 240Volt 2HP
Number of speeds: 12
Spindle taper: MT4
Spindle speeds: 210-2160rpm
Max. drilling capacity: 32mm
Max. spindle stroke: 122mm
Max. distance spindle to table: 720mm
Max. distance spindle to base: 1230mm
Chuck: 16mm
Swing: 535
Size of table: 473x410mm
Diameter of column: 92mm
Size of base: 572x495mm
Overall height: 1780mm

**Max.
DRILL
CAPACITY
32mm**

Excludes GST
\$2609
Inc. GST \$2869.90

**INDUSTRIAL
QUALITY**



Overall height: 1780mm



Scan code to go to our Top Tips guides and learn how to extend the life of your TQB Brands equipment

Visit our webpage
www.tqbbrands.com.au
for instructional & pre-start videos.

MORE THAN JUST A PRESS!

Workshop Mate Workstation featuring a 30,000KG Shop Press & Spring Compressor



FEATURES

AIR/HYDRAULIC OPERATED 30,000KG PRESS
 SPRING COMPRESSOR. FILTER CRUSHING ACCESSORY
 DOZENS OF UNIQUE TOOLING OPTIONS
 ON-BOARD TOOLING STORAGE STAND
 WINCH OPERATION TO LOWER AND RAISE BENCH

BENEFITS

Press almost any bearing or bush with **PRECISION** and **ACCURACY** in minutes, saving valuable workshop time.
 Smooth **AIR/HYDRAULIC** foot pedal operation for hands-free accuracy & control.
 Hands free Spring Compression.
 Even the most difficult pressing tasks become **SAFE & EASY**.
 Complete with **COMPREHENSIVE HIGH QUALITY** Interlocking Tool, Die and Spacer Kit to ensure **SAFE WORK PRACTICES**.
 Complete on machine storage - minimises time spent searching for the required tools & spacers for each job!
 Tasks like **SUSPENSION BUSHES** once seen as too hard become a breeze.
 A comprehensive variety of spring adaptors, suitable to almost any type or model of spring **SAFE & EASY** to compress in **MINUTES!**
 Decrease labour time & increase productivity and efficiencies.
INCREASE WORKPLACE SAFETY.
 Undertake jobs that are currently too difficult.

Safe working capacity: 30,000kg
 Working range: 224mm-819mm
 Piston ram stroke main ram:
 140mm (Standard load cap fitted)
 Bed height settings: 85mm increments-8 settings
 Bed width: 466mm Bed gap: 200mm
 Spring compressor: Piston ram stroke: 295mm
 Operating air pressure: 90-125psi
 Overall dimensions: 1820H x 1170W x 820Dmm
 Weight: 400kg

MADE FOR THE TRADE



Workshop Mate 18 Pce Sleeve Kit



18 Piece Sleeve Set includes:
 28x20x80mm; 33x25x80mm;
 38x30x80mm; 43x35x80mm;
 48x40x80mm; 53x45x80mm;
 58x50x80mm; 63x55x80mm;
 68x60x80mm; 73x65x80mm;
 78x70x80mm; 83x75x80mm;
 88x80x80mm; 93x85x80mm;
 98x90x80mm; 103x95x80mm;
 108x100x80mm; 113x105x80mm

Excludes GST
\$389
 Inc. GST \$427.90

FEATURES

18 sleeves constructed from heat-treated forged carbon steel.
 Sturdy metal carry case.
 Designed and engineered to work as an added accessory to all current Workshop Mate Workstations.



NEW



Great Workshop Mate Accessory

**Workshop Mate is designed for
Front Struts, Rear Axles
4x4 Struts Bushes & Ball Joints
Hubs & Wheel Bearings**



**Excludes GST
\$7999
Inc. GST \$8798.90**

Visit our webpage
www.tqbbrands.com.au
for more specifications
and images

***FREIGHT
RATES WILL
APPLY**

 **YouTube**
 Scan code for
online product
demonstration

***NOTE: ADDITIONAL TOOLING MAY BE REQUIRED FOR SOME APPLICATIONS**

Porta Power Kit

2011T **TRADEQUIP**
The trusted brand in equipment

Safe working capacity: 10,000kg
9 Piece Kit
Blow mould carry case: 530 x 500 x 110mm
Weight: 24kg

10,000kg Capacity

MADE FOR THE TRADE

Excludes GST
\$499
Inc. GST \$548.90



Set Includes

- 2,000kg Mini Ram - Compressed 139mm > Stroke 76mm
- 4,000kg Mini Ram - Compressed 42mm > Stroke 16mm
- 10,000kg Mini Ram - Compressed 118mm > Stroke 60mm
- 4,000kg Porta Power Ram - Compressed 276mm > Stroke 132mm
- 10,000kg Porta Power Ram - Compressed 350mm > Stroke 150mm
- 2,000kg Pull Back Ram - Extended 537mm > Stroke 128mm
- 5,000kg Pull Back Ram - Extended 613mm > Stroke 130mm
- 4 x Hooks - 2 Large and 2 Small

Porta Power Kit

BPP20T **BORUM**
INDUSTRIAL WORKSHOP EQUIPMENT

Safe working capacity: 20,000kg
Extension tubes: 125, 255, 510, 700mm
3 each, 70mm connective tube & 60mm joint connector tube
Base, Ram toe, Plunger toe
Wedge toe, V-base, Wrench
Retracted ram length: 285mm
Ram stroke: 125mm
Hydraulic hose length: 1470mm
Weight: 62kg

20,000kg Capacity

INDUSTRIAL QUALITY



FEATURES

- Constructed of high-grade steel and built to exacting standards for quality and durability.
- Lead-free paint finish is zool, grease and dirt-resistant for easy cleanup.
- High quality hydraulic steel cylinder unit helps to reduce wear and extend service life.
- Piston-ram is treated and polished.
- Hydraulics are powered with a high quality oil, which offers better corrosion resistance and high/low temperature flexibility.
- Heavy walled extension tubes stand up in tough applications.

Air/Hydraulic Pump

2054T **TRADEQUIP**
The trusted brand in equipment

Maximum output pressure: 10,000psi
Usable hydraulic fluid capacity: 2.25 Litres
Operating air pressure: 90-145 psi
Air consumption: 7.5CFM @ 100 psi
Oil delivery with No Load: 49.5 cu.in/min
Oil delivery with Load: 7.6 cu.in/min
Input (Air) port thread: 1/4" - 18 NPT
Output (Oil) port thread: 3/8" - 18 NPT

HANDS FREE POWER

MADE FOR THE TRADE



FEATURES

- Durable light-weight corrosion-free aluminium.
- Built-in overload system prevents pump from being used beyond its safety capacity.
- Ergonomic hand/foot activation lever.
- Air/oil filters minimise contaminants in hydraulic system.
- Perfect for porta power rams & bead breakers.
- Compact design fits in truck storage boxes.
- Air exhaust muffler for quiet operation.

Excludes GST
\$699
Inc. GST \$768.90

Porta Power Kit

2010T **TRADEQUIP**
The trusted brand in equipment

Safe working capacity: 10,000kg
14 Piece Kit containing pump and hose fittings
Ram length retracted: 322mm
Ram length extended: 452mm
Extensions: 110, 265, 365, 520mm
Case: 905L x 385W x 175H mm
Hydraulic hose length: 1500mm
Hydraulic oil capacity: 650ml
Adaptor diameter: 33mm
Weight: 31kg



10,000kg Capacity

MADE FOR THE TRADE

FEATURES

- Spring loaded ram return system, allowing controlled retraction of the ram.
- Pump may be used in horizontal & vertical position.
- Constructed of high-grade steel and built to exacting standards for quality and durability.
- Lead-free paint finish is oil, grease and dirt-resistant.
- Pump has an automatic overload system.
- Easily adapts to hoses, rams, pumps, spreaders, and other accessories using common 1/4" fittings.

Excludes GST
\$465
Inc. GST \$511.50

Combi Portable Bead Breaker 5,000KG

BTBB05 **BORUM**
INDUSTRIAL WORKSHOP EQUIPMENT

Working load limit: 5,000kg
Pressure connection: 3/8"-18NPTF
Rated pressure: 10,000psi
Maximum rim size: 26"
Suits 1, 2 & 3 pce rims (up to 26")
with pry bar / bead loosening pockets
Ram stroke: 90mm

FEATURES

- Durable steel construction.
- Clamps to wheel rim & breaks bead simply with up to 5,000kg of force.
- Requires 10,000psi air/hydraulic pump (sold separately).

Excludes GST
\$629
Inc. GST \$691.90

Suits Tradequip 2054T & 2054-H



INDUSTRIAL QUALITY

Giant Portable Bead Breaker 13,000KG

BTBB13 **BORUM**
INDUSTRIAL WORKSHOP EQUIPMENT

Working load limit: 13,000kg
Pressure connection: 3/8"-18NPTF
Rated pressure: 10,000psi
Suits 5 pce rims 635-1, 295mm (25"-51")
with pry bar / bead loosening pockets
Maximum rim size: 26"
Ram stroke: 105mm

FEATURES

- Economical solution for earthmover wheels 25" - 51" multi-piece rims with pry bar pockets.
- Hydraulically clamps on wheel.
- Durable steel construction.
- Hydraulic power breaks beads in seconds.
- Requires 10,000psi air/hydraulic pump (sold separately).

Suits Tradequip 2054T & 2054-H

Excludes GST
\$799
Inc. GST \$878.90



INDUSTRIAL QUALITY

Bench Vices Fixed or Swivel with Anvil



MADE FOR THE TRADE

FEATURES

Quality cast iron body with steel screw and handle. Made of tough cast iron, this TradeQuip bench vice has forged steel jaws to grip & keep your workpiece steady. The large anvil is perfect for shaping and fabrication work.



from
Excludes GST \$142
Inc. GST \$156.20

Reinforced mounting lugs

Code	7000T	7001T	7002T	7003T	7004T	7005T
Vice type	Fixed	Fixed	Fixed	Swivel	Swivel	Swivel
Jaw Width	125mm	150mm	200mm	125mm	150mm	200mm
Jaw Opening	130mm	150mm	170mm	140mm	170mm	220mm
Throat Depth	69mm	76mm	88mm	76mm	86mm	110mm
Anvil Size	85x90mm	100x105mm	105x105mm	106x106mm	127x127mm	147x147mm
Excl. GST	\$142	\$198	\$258	\$208	\$310	\$422
Incl. GST	\$156.20	\$217.80	\$283.80	\$228.80	\$341.00	\$464.20

Bench Offset Vice 150MM

7007T **TRADEQUIP**
the trusted brand in equipment

Jaw width: 150mm
Jaw opening: 140mm
Throat depth: 103mm
Weight: 21kg

Excludes GST
\$388
Inc. GST \$426.80

MADE FOR THE TRADE

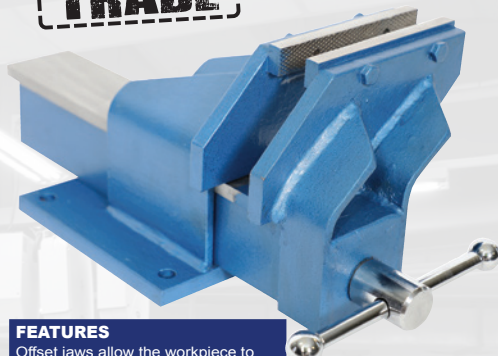

FEATURES

Offset jaws allow the workpiece to be held in a vertical position. Fixed offset base - right hand. Solid fabricated steel construction. Precision machined screw & handle.

Commercial Bench Vice Swivel with Anvil 150MM

BRV150 **BORUM**
INDUSTRIAL WORKSHOP EQUIPMENT

Jaw width: 150mm
Jaw opening: 150mm
Throat depth: 105mm
Anvil size: 90x105mm

INDUSTRIAL QUALITY



SG IRON
Excludes GST
\$419
Inc. GST \$460.90

360° Swivel Base

Multi-Purpose Bench Vice with Pipe Jaws 150MM

7009T **TRADEQUIP**
the trusted brand in equipment

Jaw width: 150mm
Jaw opening: 140mm
Throat depth: 80mm
Anvil size: 80x65mm

FEATURES

Body of rugged quality malleable cast iron. Forge hardened steel serrated jaws. Precision machined steel screw and handle. Reinforced mounting lugs. Versatile 360° Swivel base locks in place. Jaws rotate 360° and lock for unlimited positioning. Holds flat stock as well as round stock with the built-in pipe jaws. Large hardened anvil work surface.

Jaws rotate 360°

Excludes GST
\$384
Inc. GST \$422.40

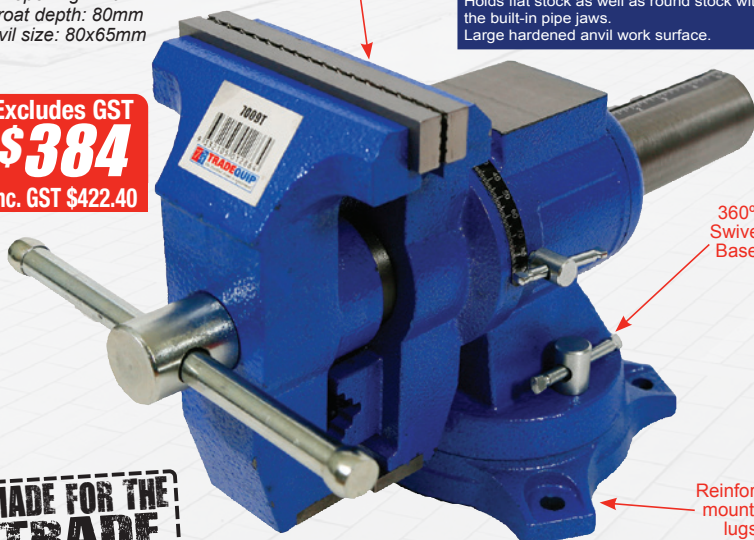

360° Swivel Base

Reinforced mounting lugs

MADE FOR THE TRADE

NOT INTENDED FOR SPRING COMPRESSING & BEARING, SLEEVE OR BUSHING PRESSING

Commercial Bench Vice Swivel with Anvil 200MM

BRV200 **BORUM**
INDUSTRIAL WORKSHOP EQUIPMENT

Jaw width: 200mm
Jaw opening: 200mm
Throat depth: 115mm
Anvil size: 100x113mm

INDUSTRIAL QUALITY



SG IRON

360° Swivel Base

Excludes GST
\$599
Inc. GST \$658.90

Parts Washer 90 Litre

1003T **TRADEQUIP**
The trusted brand in equipment

Pump power: 240V/50Hz/0.5A
Pump output: 2.7-3.3 Litres per min.
Tank: 758L x 527W x 275Hmm
Minimum fluid capacity: 18 Litres
Maximum fluid capacity: 45 Litres
Size: 780L x 540W x 908Hmm



WARNING
Do Not use cleaning fluids with a flashpoint

FEATURES
Sturdy metal construction and quality enamelled gloss finish.
Enclosed "High Volume" electric pump & fully screened pump housing.
Built-in replaceable pump inlet filter.
Chromed flexible metal fluid delivery pipe.
Large removable parts cleaning shelf for inspection and drying.
Immersion soaking when parts cleaning shelf removed.
Non welded one-piece tank with Quick Close fire safe lid mechanism.
Suitable for use with aqueous water based cleaning fluids.
Replacement parts available.

Excludes GST
\$275
Inc. GST \$302.50

Parts Washer 180 Litre

1004T **TRADEQUIP**
The trusted brand in equipment

Pump power: 240V/50Hz/0.5A
Pump output: 2.7-3.3 Litres per min.
Tank: 1135L x 545W x 320Hmm
Min. fluid capacity: 33 Litres
Max. fluid capacity: 90 Litres
Size: 1150L x 560W x 1430Hmm



WARNING
Do Not use cleaning fluids with a flashpoint

FEATURES
Sturdy metal construction and quality enamelled gloss finish.
Enclosed "High Volume" electric pump & fully screened pump housing.
Built-in replaceable pump inlet filter.
Chromed flexible metal fluid delivery pipe.
Large removable parts cleaning shelf for inspection and drying.
Immersion soaking when parts cleaning shelf removed.
Non welded one-piece tank with Quick Close fire safe lid mechanism.
Suitable for use with aqueous water based cleaning fluids.
Replacement parts available.

Excludes GST
\$455
Inc. GST \$500.50

Parts Washer Brush & Hose

1806 **TRADEQUIP**
The trusted brand in equipment

Long life 70mm synthetic bristles
Polypropylene handle
Stepped hose fitting suitable for connecting to 13mm and 16mm spouts
Suits TradeQuip parts washers
1003T, 1004T & 1050



Stiff bristles are ideal for cleaning automotive and machined parts



Excludes GST
\$27
Inc. GST \$29.70

WARNING: ONLY SUITABLE FOR USE WITH WATER BASED SOLUTIONS

Parts Cleaning Concentrate

10 & 20 Litre **TRADEQUIP**
The trusted brand in equipment



✓ **ENVIRO FRIENDLY**
✓ **BIODEGRADABLE**
✓ **NON-TOXIC**

FORMULATED FOR USE IN ALL TRADEQUIP PARTS CLEANERS

Code	5083T	5082T
Bottle contents	10 Litres	20 Litres
Creates	50 Litres	100 Litres
Exl. GST	\$88	\$139
Incl. GST	\$96.80	\$152.90



from Excludes GST
\$88
Inc. GST \$96.80

Replacement Parts Washer Pump

1005 **TRADEQUIP**
The trusted brand in equipment

Power: 230V 50Hz 26W 0.6Amp
Cable length: 305mm
Head max: 1.8m
Flowrate: 3.15 litres per minute
Outlet thread: 1/2" NPT Female
100L x 85H x 65W mm

WARNING: ONLY SUITABLE FOR USE WITH WATER BASED SOLUTIONS



Excludes GST
\$84
Inc. GST \$92.40



FEATURES

Sturdy poly/plastic body. Stainless steel shaft.
Suits parts washers with chromed flexible metal fluid delivery pipes.
Snap off inlet grill for easy cleaning.
Suitable for use with aqueous water based cleaning fluids.
Works with TradeQuip parts washers (Code/s 1003T, 1004T and 1050, sold separately)

DESIGNED FOR AUTOMOTIVE & INDUSTRIAL APPLICATION

6 Litres **TRADEQUIP** *The trusted brand in equipment*

Capacity: 6 Litres
Ultrasonic power: 150W
Ultrasonic frequency: 40KHz
Heating power: 300W
Heating temperature: 20-80 C

Timer range: 0-30 Minutes
Tank material: 304 Grade 2mm thick
Tank size: 300L x 155W x 150Hmm
Size: 330L x 180W x 310Hmm

1036T

Excludes GST
\$955
Inc. GST \$1050.50



13 Litres **TRADEQUIP** *The trusted brand in equipment*

Capacity: 13 Litres
Ultrasonic power: 300W
Ultrasonic frequency: 40KHz
Heating power: 400W
Heating temperature: 20-80 C

Timer range: 0-30 Minutes
Tank material: 304 Grade 2mm thick
Tank size: 330L x 300W x 150Hmm
Size: 360L x 330W x 310Hmm

1037T

Excludes GST
\$1599
Inc. GST \$1758.90



MADE FOR THE TRADE

- * 30 Minute Timer
- * Adjustable Temp. Control
- * 304 Grade Stainless Steel Tank



DON'T BE FOOLED BY CHEAPER IMITATIONS THAT ARE DESIGNED FOR DENTISTRY, MODEL BUILDING, OPTOMETRY & LIGHTER DUTIES

27 Litres **TRADEQUIP** *The trusted brand in equipment*

Capacity: 27 Litres
Ultrasonic power: 500W
Ultrasonic frequency: 40KHz
Heating power: 500W
Heating temperature: 20-80 C

Timer range: 0-30 Minutes
Tank material: 304 Grade 2mm thick
Tank size: 500L x 300W x 200Hmm
Size: 550L x 330W x 360Hmm

1038T

Excludes GST
\$2119
Inc. GST \$2330.90



36 Litres **TRADEQUIP** *The trusted brand in equipment*

Capacity: 36 Litres
Ultrasonic power: 600W (adjustable)
Ultrasonic frequency: 28/40KHz
Heating power: 800W
Heating temperature: 20-80 C

Timer range: 0-30 Minutes
Tank material: 304 Grade 2mm thick
Tank size: 500L x 290W x 250Hmm
Size: 570L x 360W x 450Hmm

1039T

Excludes GST
\$3499
Inc. GST \$3848.90



MADE FOR THE TRADE

- * 30 Minute Timer
- * Adjustable Temp. Control
- * 304 Grade Stainless Steel Tank

FEATURES

TradeQuip "Made for the Trade" Ultrasonic Parts Cleaners make it easy to clean items like carbies, calipers, nuts & bolts, most small metal parts - even jewelry. Just fill the cleaner with water, mix with the appropriate ultrasonic cleaning additive (sold separately), set the timer and walk away to get on with another job. The ultrasonic cleaner works with or without heat and provides deep cleaning using ultrasound technology and water. The adjustable temperature and timer gives you a variety of cleaning performance options.

LARGER SIZES AVAILABLE FOR SPECIAL ORDER. PLEASE ENQUIRE WITH YOUR PREFERRED DISTRIBUTOR

Blasting Cabinet 220 Litre Capacity

3051 **TRADEQUIP**
the trusted brand in equipment

Cabinet capacity: 220 Litre
Working pressure: 60-110psi
Maximum media capacity: 20kg
4 Ceramic nozzle tips: 4, 5, 6 & 7mm
With gun & low voltage internal fluorescent light
Tempered glass view window: 250 x 525mm
External size: 1400H x 890L x 550Wmm

Includes gun and light



Tempered glass window

Side opening door

Suitable for use with workshop vacuum

220 LITRE Capacity

FEATURES

Freestanding floor model. Complete with gun and low voltage internal fluorescent light. Tempered glass viewing window with protective shields. Cabinet fitted and ready to be used with a workshop vac as dust collection system. Spare parts available in Australia.

MADE FOR THE TRADE



Excludes GST
\$849
Inc. GST \$933.90

Blasting Cabinet 420 Litre Capacity

3036T **TRADEQUIP**
the trusted brand in equipment

Cabinet capacity: 420 Litre
Air regulator & gauge panel
4 Ceramic nozzles: 2x5mm, 2x6mm
Maximum media capacity: 70kg
Maximum air pressure: 125psi
Required air supply: 15-25CFM
14 gauge steel legs & 16 gauge panels
Sand blasting efficiency: 100cm²/min
Optimum operating pressure 60-110psi
External size: 1680H x 1180W x 940Dmm



Oversized hinged top door opening

Includes 240V dust extraction system

420 LITRE Capacity

MADE FOR THE TRADE



Includes blasting gun & vinyl blaster gloves

FEATURES

Perfect for surface preparation on any type where other forms of preparation are difficult. Ideal for removing paint, rust, scale and oxidation. Large viewing window gives the operator a wide viewing area. Oversized hinged top door opening & large inside work area allows easy maneuverability. Hinged door on hopper allows for easy abrasive changes. Fluorescent light kit and 90CFM dust collector help the operator to maintain a good visual. Rear-mounted dust collector. Replaceable protective window. Foot-pedal-controlled siphon blast gun.



Excludes GST
\$3099
Inc. GST \$3408.90

Foot operated pressure control valve

TRADEQUIP
the trusted brand in equipment

BLASTING MEDIA ABRASIVE

TradeQuip "Made for the Trade" Blasting Media Abrasives are designed for use in conjunction with our TradeQuip Mobile Blasting Kits and Blasting Cabinets. Abrasive blasting has been used for many years to clean and remove rust, paint and corrosion. There are many types of abrasive media available, the most common being Garnet, Steel Grit and Glass Bead. These media have an aggressive cut and can rapidly remove paint and rust. However, they can also generate significant heat, potentially resulting in warped metal and etched surfaces, and they cannot be used on fiberglass. Also, chrome, plastic, rubber, trim, and other parts must be removed from a work surface or masked-off before blasting. Alternatively, less-aggressive media, such as Walnut Shell, will do a great job at removing paint. Walnut Shell does not generate as much heat as other media, and can be used on sheet metal and fiberglass without damaging the base material. However, Walnut Shell as with any abrasive media, will require more clean-up as it leaves particles in the car body's seams and crevices that can be difficult to completely remove. Soda blasting media has non abrasive properties which makes it a very universal blasting media which can be applied to lighter materials such as aluminium, plastic, fiberglass, wood etc. Soda Blasting does not damage glass, rubber, chrome items if they are left on a vehicle for blasting.

GARNET 25KG MEDIUM 30/60 3020T

Garnet is a gemstone with excellent naturally abrasive properties. This hard abrasive is fast-cutting, low-dust producing and low-consuming, excellent for removing tough coatings, paint, rust and mill scale from steel. Garnet also permits precise feathering control. A good general outdoor surface preparation abrasive.



Excludes GST
\$58
Inc. GST \$63.800

GARNET 25KG FINE 35/100 3021T (Australian Mined)

Garnet is a gemstone with excellent naturally abrasive properties. This hard abrasive is fast-cutting, low-dust producing and low-consuming, excellent for removing tough coatings, paint, rust and mill scale from steel. Garnet also permits precise feathering control. A good general outdoor surface preparation abrasive.



Excludes GST
\$66
Inc. GST \$72.050

WALNUT SHELLS 20KG 6-100 MICRON 3022T

Walnut Nut shells and other organic materials, don't cause anchor patterns, making them useful for removing dirt, grease, oil, carbon, scale, burrs and paint without changing the underlying substrate. Walnut shells can be an excellent choice for softer surfaces such as wood — they won't cause etching. Walnut shells are one of less abrasive blasting media you can use and are completely biodegradable, making them among the most environmentally-friendly blasting media.



Excludes GST
\$179
Inc. GST \$196.90

GARNET 25KG COARSE 20/40 3023T

Garnet is a gemstone with excellent naturally abrasive properties. This hard abrasive is fast-cutting, low-dust producing and low-consuming, excellent for removing tough coatings, paint, rust and mill scale from steel. Garnet also permits precise feathering control. A good general outdoor surface preparation abrasive.



Excludes GST
\$62
Inc. GST \$68.20

GLASS BEAD 25KG 106-300MICRON 3025T

Glass beads are used for general cleaning, peening and cosmetic finishing of sensitive metal surfaces; removing automotive paint; brightening grout and removing fungus and calcium deposits from tile; polishing cast iron, stainless steel, aluminium, propellers and turbine blades. Glass Beads are environmentally friendly and can be used in many blast applications to provide a finish with no profile. Use while working with metal, plastic or rubber materials to clean, debur and finish.



Excludes GST
\$99
Inc. GST \$108.90

SODA BI CARB 22KG 3028T (Product of America)

Clean tools, strip paint and more with Soda Bi-Carbonate. The medium-sized crystals provide blasting power to smooth and strip paint without damaging other surfaces. Works with aluminum, steel, stainless steel, fiberglass and more...



Excludes GST
\$135
Inc. GST \$148.50

Soda/Sand Blasting Hood

3053 **TRADEQUIP**
the trusted brand in equipment

Durable fabric & synthetic-leather construction
Large 110mm x 55mm acrylic viewing plate
Adjustable internal helmet for added comfort
Reinforced side ventilation panels for increased airflow

FEATURES

Protect eyes and face from "rebounding" abrasive particles by wearing Abrasive Blasting Hood. Ideal for many abrasive-blasting applications.

Excludes GST
\$52
Inc. GST \$57.20

MADE FOR THE TRADE



NOT FOR RESPIRATORY PROTECTION

Motorcycle Lifter 360KG

2102T **TRADEQUIP**
The trusted brand in equipment

Safe working capacity: 360kg
Height: 205 - 780mm
Platform: 490W x 1345Lmm
Weight: 95kg

MADE FOR THE TRADE



Features wide lifting stability

360kg Capacity

Excludes GST
\$929
Inc. GST \$1021.90

Motorcycle Scissor Lift 500KG

2104T **TRADEQUIP**
The trusted brand in equipment

Safe working capacity: 500kg
Height: 95 - 420mm
Platform dimensions: 450x150mm
Weight: 13.8kg

MADE FOR THE TRADE

FEATURES

Designed to deliver the ideal lift for use with motorcycles, ATV's, tractors, personal watercraft, and snowmobiles.
Lifts back wheel off lift table for tyre/wheel change.
Powder coated structural heavy duty steel construction.
Rotate lead screw to adjust & raise the lift.
Bolt down lugs to prevent unwanted movement.

Excludes GST
\$165
Inc. GST \$181.50



Motorcycle Lifter 450KG

2101T **TRADEQUIP**
The trusted brand in equipment

Safe working capacity: 450kg
Height: 175 - 750mm
Platform: 680W x 2200Lmm
Weight: 120kg

MADE FOR THE TRADE

Excludes GST
\$1189
Inc. GST \$1307.90



450kg Capacity

FEATURES

Ideal lift for use with motorcycles, ATV's, tractors, personal watercraft & snowmobiles.
Locking bar for safety.
Powder coated structural heavy duty steel.
Extra Long Full width loading ramp.
Step-less rate of lowering irrespective of load.
Oil trap plate for easy drainage.
2 foot pedals for raising & lowering - for easy hands free operation.
Fitted with 2 position platform locking device to prevent accidental lowering.
Quality wheels and swivel castors making it easier to position and move around.
Lockdown bolts to prevent unwanted movement during use.
Does not include tie down straps.

Motorcycle Lifter Air Actuated 680KG

2103T **TRADEQUIP**
The trusted brand in equipment

Safe working capacity: 680kg
Height: 185 - 825mm
Platform dimensions: 710 x 2000mm
Required air pressure: 0.75-0.85Mpa
Weight: 169kg

OPTIONAL EXTRA

Side Extensions
2103T-EXT



Excludes GST
\$2099
Inc. GST \$2308.90

MADE FOR THE TRADE

680kg Capacity



FEATURES

Designed to deliver the ideal lift for use with motorcycles, ATV's, tractors, personal watercraft, and snowmobiles.
Locking bar for safety.
Extra long full width loading ramp.
Powdercoated structural heavy duty steel.
Stepless rate of lowering irrespective of the load.
Oil trap plate for easy drainage.
Lockdown bolts.
2 foot pedals for raising & lowering - for easy hands free operation.
Fitted with 2 position platform locking device.



ABOUT EAGLE PRO HYDRAULICS

With nearly 3 decades experience of manufacturing hydraulic tools for industrial applications, Eagle Pro Hydraulics has become the trusted partners for applications spanning from offshore plant maintenance to mining, infrastructure, commercial and industrial. Eagle Pro Hydraulics are manufactured to ISO 9001:2018 through international quality assurance programs which involve consistent observation of administration, management, manufacturing and production control. Eagle Pro hydraulic cylinders meet or exceed ANSI B30.1. This results in reliable and dependable high-quality products you can count on every time.

ES SERIES

Single Acting General Purpose

Eagle Pro ES series redefines durability for the harshest of industrial environments with its high strength alloy steel construction. Hardened and chromed piston ensures superior product life by reducing wear and corrosion. Eagle Pro ES series is not only durable, it gets the job done! Heavy-duty, straight pull return springs provide fast retraction. For greater flexibility and easy mounting, the ES series comes with collar, multiple piston threads, and base mounting holes. Hardened and E-coated snap-in type saddle prevents piston jamming and mushrooming, practically eliminating downtime. The female coupler comes with a dust cover - preventing dirt and debris from entering the hydraulic system. The Eagle Pro ES series also complies with ASME B30.1 standard.



EDH SERIES

Double Acting Hydraulic

The Eagle Pro EDH series incorporates a hollow piston design that allows both pushing and pulling forces. The construction of high strength alloy steel maximizes durability. The EDH series' double acting operation ensures fast and controlled piston reaction time. Accidental over-pressurization is prevented with a built-in safety valve. The collar, piston threads, and base mounting holes enable easy fixturing.



ED SERIES

Double Acting General Purpose

The Eagle Pro ED series produces fast and controlled piston contraction thanks to the double acting operation. A built-in safety valve prevents accidental-over pressurization. Most models include collar, piston threads, and base mounting holes to make fixturing a simple task. Piston jamming and mushrooming is prevented by the cylinder's hardened, and E-coated snap-in saddle. The ED series enhances durability with a hardened and chromed piston that reduces wear and corrosion. ED series cylinders are easy to move around the job site with the addition of carrying handles (and eyebolts on larger models) that ease positioning and carrying. A durable, anti-corrosive finish is added using an environmentally friendly coating process.



EDX SERIES

Double Acting High Tonnage

Eagle Pro EDX series maximizes durability with the use of a high strength alloy steel. The built-in safety valve prevents accidental over-pressurization. The EDX is easy to carry and position with the included eyebolts. Optional tilt saddles are also available. The hardened and chromed piston minimizes wear and corrosion damage. The incorporation of base mounting holes enables easy fixturing. An environmentally friendly coating process provides a highly durable finish.



EL SERIES

Single Acting With Locking Collars

The Eagle Pro EL series includes an alloy steel lock nut for mechanical load holding. The EL series is constructed of a high strength alloy steel to maximize durability. The hardened chrome piston reduces damage caused from wear and corrosion. The over flow port functions as a stroke limiter. The EL series includes hardened grooved replaceable saddles. Composite bearings prevent metal-to-metal contact. Quick reaction times are obtained through with heavy-duty straight pull return springs. An environmentally friendly coating process produces a finish that further increases durability.



ESL SERIES

Low Profile And Pancake Style

Featuring a low-profile, or flat design, the Eagle Pro ESL series cylinder is an optimal choice for confined spaces. The hardened and chromed piston is constructed of high strength alloy steel that increases durability by reducing wear and corrosion. The grooved piston end does not require a saddle and the inclusion of mounting holes permits easy fixturing. Retraction time is quick thanks to the heavy duty, straight pull return springs. An environmentally friendly coating process is used to provide the durable anti-corrosion finish.



ESH SERIES

Single Acting Hollow Piston

The Eagle Pro ESH Series allows for both pushing and pulling by incorporating a hollow piston design. The heavy-duty return spring provides notoriously quick reaction times. Easy fixturing with the inclusion of collar threads.



EPA SERIES

Dual Speed Hand Pumps

The Eagle Pro EPA series hydraulic hand pumps are some of the most durable, powerful and reliable hand pumps in the industry today. The EPA series feature valve blocks that are machined from a single piece of high strength aircraft grade aluminum and high capacity reservoirs made from alloy steel* that maximizes durability. The EPA series hand pumps are compact and easy to carry around the job site. To get the job done faster, these powerful dual speed pumps offer some of the best flow rates in the industry. All of the EPA series hydraulic hand pumps feature an internal safety valve to prevent system damage.



EAGLE PRO

HYDRAULICS



Model	Description	Cylinder Capacity @ 10,000PSI (700 BAR)	Stroke	Cylinder Effective Area	Oil Capacity	Collapsed Height	Extended Height	Price ex GST	Price inc GST
		Metric Kg				MM	MM		
						CM ²	CM ³		
ES-50	SINGLE ACTING RAM	5,000	16	7.1	11.4	42	58	\$399.00	\$438.90
ES-51	SINGLE ACTING RAM	5,000	25	7.1	17.8	110	135	\$489.00	\$537.90
ES-55	SINGLE ACTING RAM	5,000	127	7.1	90.2	215	342	\$619.00	\$680.90
ESL-50	SINGLE ACTING RAM PANCAKE STYLE	5,000	6	7.1	4	33	39	\$389.00	\$427.90
ES-1010	SINGLE ACTING RAM	10,000	257	14.5	372.65	349	606	\$799.00	\$878.90
ES-102	SINGLE ACTING RAM	10,000	54	14.5	78.3	121	175	\$489.00	\$537.90
ES-106	SINGLE ACTING RAM	10,000	156	14.5	226.2	247	403	\$799.00	\$878.90
ESL-100	SINGLE ACTING RAM PANCAKE STYLE	10,000	10	14.5	15	42	53	\$569.00	\$625.90
ESL-101	SINGLE ACTING RAM PANCAKE STYLE	10,000	38	14.4	55	88	126	\$599.00	\$658.90
ESH-121	SINGLE ACTING RAM HOLLOW PISTON	13,000	42	18.4	77.3	120	162	\$696.00	\$1065.90
ES-1510	SINGLE ACTING RAM	15,000	254	21.2	538.48	373	627	\$1099.00	\$1208.90
ES-1514	SINGLE ACTING RAM	15,000	356	21.2	754.72	474	830	\$1199.00	\$1318.90
ES-152	SINGLE ACTING RAM	15,000	51	21.2	108.12	149	200	\$759.00	\$834.90
ES-154	SINGLE ACTING RAM	15,000	101	21.2	214.12	200	301	\$929.00	\$1021.90
ESH-206	SINGLE ACTING RAM HOLLOW PISTON	20,000	49	32.8	161	162	211	\$1749.00	\$1923.90
ESL-200	SINGLE ACTING RAM PANCAKE STYLE	20,000	11	28.3	31	51	62	\$699.00	\$768.90
ESL-201	SINGLE ACTING RAM PANCAKE STYLE	20,000	45	28.3	127	98	143	\$769.00	\$845.90
ES-251	SINGLE ACTING RAM	25,000	26	33.2	86.32	139	165	\$999.00	\$1098.90
ES-252	SINGLE ACTING RAM	25,000	50	33.2	166	165	215	\$1079.00	\$1186.90
ES-254	SINGLE ACTING RAM	25,000	102	33.2	338.64	215	317	\$1179.00	\$1296.90
ES-256	SINGLE ACTING RAM	25,000	158	33.2	524.56	273	431	\$1349.00	\$1483.90
ESH-302	SINGLE ACTING RAM HOLLOW PISTON	30,000	64	48	307	179	242	\$1888.00	\$2076.80
ESH-306	SINGLE ACTING RAM HOLLOW PISTON	30,000	156	48	744	330	485	\$1999.00	\$2198.90
ESL-300	SINGLE ACTING RAM PANCAKE STYLE	30,000	13	41.8	54	58.5	71	\$1055.00	\$1160.50
ESL-302	SINGLE ACTING RAM PANCAKE STYLE	30,000	62	41.8	259	117	179	\$979.00	\$1076.90
EL-506	SINGLE ACTING RAM LOCKING COLLAR	50,000	150	70.8	1062	264	414	\$1929.00	\$2121.90
ES-502	SINGLE ACTING RAM	50,000	51	70.9	361.59	176	227	\$1229.00	\$1351.90
ES-506	SINGLE ACTING RAM	50,000	159	70.9	1127.31	282	441	\$1699.00	\$1868.90
ESL-500	SINGLE ACTING RAM PANCAKE STYLE	50,000	16	63.6	102	67	83	\$979.00	\$1076.90
ESL-502	SINGLE ACTING RAM PANCAKE STYLE	50,000	60	63.6	382	122	182	\$1199.00	\$1318.90
ESH-603	SINGLE ACTING RAM HOLLOW PISTON	60,000	76	87.4	664	247	322	\$2549.00	\$2803.90
EL-1002	SINGLE ACTING RAM LOCKING COLLAR	100,000	50	132.7	663.5	187	237	\$2399.00	\$2638.90

Model	Description	Cylinder Capacity @ 10,000PSI (700 BAR)	Stroke	Max. Cylinder Capacity		Cylinder Effective Area		Oil Capacity		Price ex GST	Price inc GST
				Advance	Retract	Advance	Retract	Advance	Retract		
				Metric Kg	MM	METRIC TON	METRIC TON	CM ²	CM ²		
EDX-506	DOUBLE ACTING RAM	50,000	150	53	26	75.4	36.9	1,131	1,131	\$1799.00	\$1978.90
EDX-1006T	DOUBLE ACTING RAM	100,000	150	93	43	132.7	61.9	1,991	928	\$2549.00	\$2803.90
EDH-307	DOUBLE ACTING RAM HOLLOW PISTON	30,000	178	33	22	47.7	32.4	849	577	\$2249.00	\$2473.90
EDH-603	DOUBLE ACTING RAM HOLLOW PISTON	60,000	89	60	39	87.4	56.2	778	481	\$2549.00	\$2803.90
EDH-606	DOUBLE ACTING RAM HOLLOW PISTON	60,000	166	60	39	87.4	56.2	1451	891	\$3199.00	\$3518.90
ED-1012	DOUBLE ACTING RAM	10,000	305	10	3	14.5	4.9	443	149.5	\$1799.00	\$1978.90

Model	Description	Cylinder Type	Speed	Usable Oil Volume	Pressure Rating		Oil Displacement Per Stroke		Handle Force	Price ex GST	Price inc GST
					1st Stage	2nd stage	1st Stage	2nd Stage			
					CM ³	BAR	BAR	CM ³			
EPA-10921A	HAND PUMP, S/A, TWO SPEED, 55 IN3	SINGLE ACTING	TWO	750	25	700	33	3.3	49	\$699.00	\$768.90
EPA-12321A	HAND PUMP, S/A, TWO SPEED, 140 IN3	SINGLE ACTING	TWO	2300	25	700	33	3.3	49	\$1019.00	\$1120.90
EPA-12322A	HAND PUMP, D/A, TWO SPEED, 140 IN3	DOUBLE ACTING	TWO	2300	25	700	33	3.3	49	\$1039.00	\$1142.90

Model	Description	Internal Diameter	Length	Hose Material	Working Pressure	Burst Pressure	Hose End Configuration		Price ex GST	Price inc GST
		MM	MM		PSI	PSI	Pump End	Cylinder End		
EH-8206F	1/4" IDX6' RBR HYDHOSE 3/8" NPT EAB-201B	6	1800	-	10,000	20,000	3/8" NPT	3/8" NPT	\$199.00	\$218.90

Model	Description	Max. Pressure	Type	Thread	Female Coupler	Male Coupler	Price ex GST	Price inc GST
		PSI		IN				
EAB-201	3/8" MALE/FEMALE HIGH FLOW QUICK	10,000	HIGH FLOW	3/8" - 18NPT	EAB-201A	EAB-201B	\$85.00	\$93.50

Model	Description	Pressure Range		Thread	Gauge Diameter	Price ex GST	Price inc GST
		PSI	MPa	IN	IN		
EG-2510	2.5 IN. 15,000 PSI PRESSURE GAUGE	0 - 15,000	0 - 100	1/4" - NPT	2.5	\$239.00	\$262.90

Model	Description	Male Coupler Thread	Female Coupler Thread	Gauge Port Thread	Price ex GST	Price inc GST
		IN/D	IN/E	IN/C		
EGA-005	GAUGE ADAPTOR	3/8" - NPT	3/8" - NPT	1/4" - NPT	\$89.00	\$97.90

Model	Description	Cylinder Capacity @ 10,000 PSI (700 BAR)	Oil Capacity	Tip Clearance	Maximum Spread Distance	Cylinder Effective Area	Weight	Price ex GST	Price inc GST
		US TON	CM ³	MM/A	MM/B	CM ²	KGS		
EFS-14	14 TON HYDRAULIC SPREADER	14	78.33	6.09	81.02	14.51	7.17	\$2389.00	\$2627.90





Air/Hydraulic Workshop Press

45,000KG WIDE

45,000kg Capacity

2038T

Safe working capacity: 45,000kg

Working range: 159-859mm

Bed outside: 359mm

Bed inside: 195mm

Bed width: 826mm

Piston ram stroke: 190mm

Ram diameter: 90mm

Operating air pressure: 110-125 psi

1707H x 1420W x 800Dmm

Bed height settings: 6

Weight: 301kg

AIR OPERATED

6 HEIGHT SETTINGS

FEATURES

- High-grade steel frame.
- 2 speed pump. 100mm pressure gauge.
- Bed winch for easy raise and lower adjustment.
- Paint is oil, grease and dirt-resistant for easy cleanup.
- High quality large diameter hydraulic steel cylinder unit.
- Piston-ram is treated, polished.
- Includes hand winch.
- Integrated overload protection valve prevents overloading.
- Extra-long handle included for easy pumping.
- Double spring ram return for fast ram retraction.

MADE FOR THE TRADE



BONUS
12 MONTH PARTS ONLY WARRANTY ON HYDRAULIC RAM & HYDRAULIC PUMP IN ADDITION TO STANDARD 12 MONTH WARRANTY***



Excludes GST
\$3499
Inc. GST \$3848.90

THIS IS A PRICED PRODUCT GUIDE WITH RTP VALID TO 31 MARCH 2025. AT TIME OF GOING TO PRINT, EXCLUDING SOME NEW PRODUCTS, STOCK IS PLENTIFUL WITH REPLENISHMENT STOCK IN PRODUCTION AND SHIPPING. AT THE TIME THAT YOU PLACE YOUR ORDER, YOUR PRODUCT MAY NOT BE IN STOCK BUT AN ETA WILL BE PROVIDED. OUR BEST EFFORTS ARE BEING MADE TO MAINTAIN STOCK LEVELS OF PRODUCTS FEATURED IN THIS CATALOGUE. BUT THE SITUATION REMAINS FLUID DUE TO BOTTLENECKS IN GLOBAL SUPPLY CHAINS. YOUR PREFERRED DISTRIBUTOR WILL BE UPDATED AS SOON AS PRACTICAL WITH ANY INFORMATION AFFECTING THIS PUBLICATION. PRODUCTS DISTRIBUTED BY TQB BRANDS PTY LTD ARE DESIGNED, INTENDED & MARKETED FOR TRADE AND COMMERCIAL USE ONLY. ERRORS AND OMISSION EXCEPTED. *FREIGHT COST MAY APPLY ON BUY-IN LINES, SPECIAL ORDER PRODUCTS, NONE STOCK LINES, LARGE OVERSIZE ITEMS & IN REGIONAL AREAS. ***UNLESS STATED OTHERWISE, ALL TQB BRANDS PRODUCTS, EXCLUDING CONSUMABLES, COME WITH A 12 MONTH COMMERCIAL USE WARRANTY AGAINST MANUFACTURING DEFECTS. THE BONUS 12 MONTH WARRANTY OFFERED EXCLUSIVELY IN THIS PROMOTIONAL PERIOD APPLIES ONLY TO THE HYDRAULIC RAM AND HYDRAULIC PUMP FOR 'BONUS' MARKED PRODUCTS. THE ADDITIONAL 12 MONTHS DOES NOT INCLUDE INSTALLATION/REMOVAL LABOUR OR FREIGHT FOR THE COMPONENT.